

PRELIMINARY



164 kW (Stage IIIa)

186 kW (Stage V)



120 t



40 m



**MAX CAB**

# 6113E

Mobile telescopic crane

Stage V

# 6113E Advanced. The E-Series.



Telescopic crane TX10-1982

## What makes up the E-Series

- Over 30 years of experience in designing and constructing telescopic cranes
- Uncompromisingly high performance in all areas
- Technology that can be mastered: High-quality components without over-engineering
- Long service life and high value stability

## Your top benefits

1

### Green Efficiency

Save fuel - reduce operating costs  
Work quietly - protect operator and environment



2

### Top-level performance

Robust boom system  
2 equivalent crane winches - high cable speed

3

### Maximum usability

Maxcab comfort cab - work in comfort  
SENCON - work program selection made easy



4

### Flexible operation

Operate under load - small space requirements  
Telescoping under load with the full-power boom

5

### Easy to transport

Mobile undercarriage - quickly deployable

6

### Maintenance and service made easy

SENNEBOGEN control system - easy error diagnosis  
Simple maintenance - clear labeling

7

### Consultation and support in your area

3 production sites - 2 subsidiaries  
150 sales partners - over 350 service stations

» Pick & Carry

max.  
28 t  
at 5.5 m



# 6113E Technical data, equipment

## MACHINE TYPE

Model (type) **6113**

## ENGINE

Model	Cummins diesel engine B 6.7 <b>186 kW / 253 hp at 2000 min<sup>-1</sup></b> Stage V emissions
	Cummins diesel engine QSB 6.7 <b>164 kW / 223 hp at 2000 min<sup>-1</sup></b> Stage IIIa emissions
	Direct injection, turbocharged, charge air cooling, reduced emissions
Cooling	water-cooled
Diesel filter	with water separator and heater
Air filter	Dry filter with integrated pre-separator, automatic dust discharge, main element and safety element, contamination indicator
Fuel tank	<b>450 l</b>
DEF tank	<b>45 l</b>
Electr. system	<b>24 V</b>
Batteries	<b>2 x 155 Ah</b> battery disconnect switch
Option	<ul style="list-style-type: none"> <li>■ Electric fuel pump</li> </ul>

## UPPERCARRIAGE

Design	Torsion-resistant box design, precision crafted, steel bushings for boom bearings. Very service-friendly design, engine installed in the longitudinal direction
Electrical system	central electrical distributor, battery disconnect switch
Cooling system	3-circuit cooling system with high cooling output, thermostatically regulated fan drive for oil cooler, electronically regulated water and charge air cooler
Safety	<ul style="list-style-type: none"> <li>■ Camera monitoring of the rear area and right side</li> <li>■ LED lighting packages</li> <li>■ Upper-carriage railing</li> </ul>
Options	<ul style="list-style-type: none"> <li>■ Additional LED headlamps</li> <li>■ Up to 2 additional cameras</li> <li>■ Anti-corrosive maritime climate varnish</li> <li>■ Low-temperature package for use at temperatures below -20 °C</li> </ul>

## Options

- Automatic central lubrication for boom attachment point, luffing cylinder, slewing ring track and winch drum bearings
- Pinion tooth lubrication for slewing ring

## HYDRAULIC SYSTEM

	Load-sensing/ LUDV hydraulic system, electro-hydraulic work functions, load limit sensing control
Pump type	Swash plate-type variable-displacement piston pump, load pressure-independent flow distribution for simultaneous, independent control of work functions
Pump control	Zero-stroke control, on-demand flow control – the pumps only pump as much oil as will actually be used, pressure purging, load limit sensing control
Operating pressure	up to <b>330 bar</b>
Filtration	High-performance filtration with long change interval
Hydraulic tank	<b>1125 l</b>
Control system	Proportional, precision electro-hydraulic actuation of work movements, 2 hydraulic servo joysticks for the work functions incl. winch motion detector via vibration transmitter, additional functions via switches and foot pedals
Safety	Hydraulic circuits secured with safety valves Pipe-fracture safety valves for luffing cylinder and telescopic cylinder
Options	<ul style="list-style-type: none"> <li>■ Bio-oil – environmentally friendly</li> <li>■ 3 µm hydraulic micro-filter SENNEBOGEN HydroClean</li> <li>■ Electric hydraulic tank preheating for temperatures below -20 °C</li> </ul>

## ROTARY DRIVE

Gearbox	2 compact planetary gears with bent-axis hydraulic engine, integrated brake valves
Swing bearing brake	Spring-loaded multi-disk brake, foot pedal for individual brakes
Slewing ring	Externally geared slewing ring, sealed
Slewing speed	<b>0-2 min<sup>-1</sup></b> , variable

# 6113E Technical data, equipment

CAB 	
Cab type	Spacious Maxcab, tiltable 20°
Cab equipment	Sliding door, sliding window in operator door, excellent ergonomics, automatic air conditioning, seat heater, air-suspension comfort seat, fresh air /circulating air filter, 12 V/24 V connections, SENCON, sunblind for skylight
Options	<ul style="list-style-type: none"> <li>■ Hydraulically elevating cab type E270, can elevate up to 2.70 m and tilt by 30°</li> <li>■ Auxiliary heating system with timer</li> <li>■ Activated-carbon filter for cab</li> <li>■ Bullet proof windshield</li> <li>■ Bullet proof skylight</li> <li>■ FOPS protective roof grating</li> <li>■ Radio with USB and SD connections, MP3 and Bluetooth functions</li> <li>■ Work area limitation</li> </ul>

ATTACHMENTS 	
Design	Decade-long experience, most advanced computer simulation, the greatest degree of stability and longest service life, large-scale mounting points and precision-crafted sealed low-maintenance special bushings
Telescopic boom	4 part with pulley head, hydraulic telescopic extension from 12.6 - 40.2 m
Hub winch	Bent-axis hydraulic engine drive with compact planetary gear, 125 kN tensile force, cable speed 0 - 115 m/min., cable diameter 26 mm, cable length 175 m. Winch motion detector via vibration transmitter in the joysticks
Safety brake	Spring-loaded multi-disk brake
Crane safety	Latest generation of load moment monitoring, clear operations panel showing all important data via the SENCON display, lifting limit switch, cable exit protection, pressure relief valves and burst pipe protection with event recorder
Cylinders	Hydraulic cylinders with high-quality sealing and guide elements
Options	<ul style="list-style-type: none"> <li>■ Electro-hydraulic emergency unit 7.5 kW</li> <li>■ Auxiliary boom: 36 t load capacity</li> <li>■ 2. Crane winch: 125 kN tensile force, cable speed 0-115 m/min., cable diameter 26 mm, cable length 175 m</li> <li>■ Radio remote control</li> </ul>

UNDERCARRIAGE 	
Design	Mobile undercarriage M580 with integrated 4-point suspension, steering axle as hydraulically locking pendulum axle. Pendulum axle cylinder with pipe fracture safety valves.
Drive	All-wheel drive powered by a variable-displacement hydraulic engine with direct-mounted, automatically operated brake valve and planetary axles with integrated steering cylinder, 2-circuit multi-disk service brake
Parking brake	Spring-loaded multi-disk brake
Tires	23.5-25, 4x
Speed	<b>0 - 10 km/h</b>

OPERATING WEIGHT 	
Mass	<b>approx. 85,500 kg</b> with 40.2 m telescopic boom, 80 t hook, 2 hoisting winches, ballast 19.2 t
Note	Operating weight varies with equipment.



# 6113E Crane equipment



Main boom HA 40.2 m

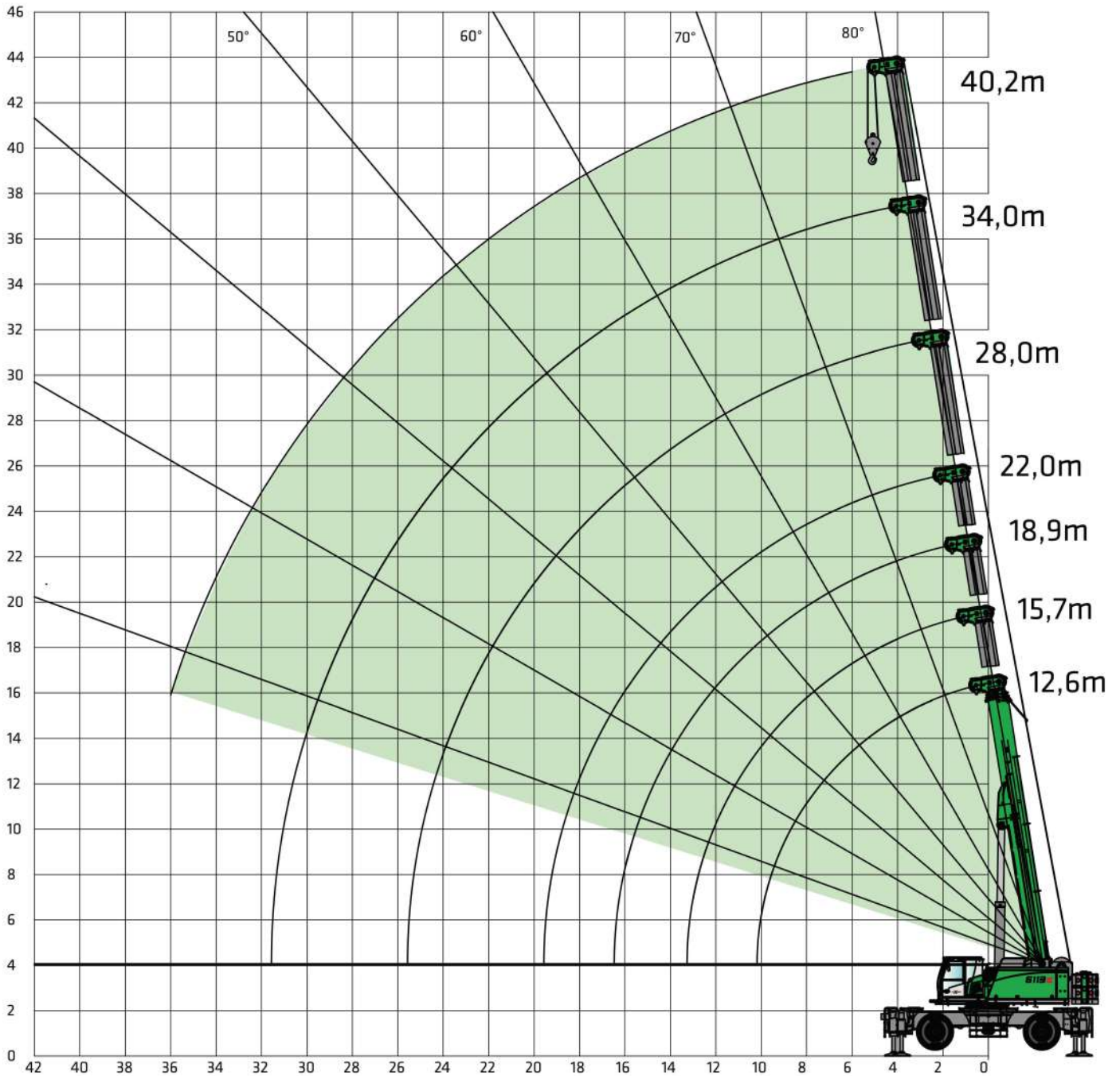

# 6113E Load ratings



Main boom HA 40.2 m  
outrigger-supported 100 %

Reach [m]	Boom length [m]						
	12.6	15.7	18.9	22.0	28.0	34.0	40.2
2.5	120.0						
3.0	100.0						
4.0	84.0	69.0	66.0	52.0			
5.0	75.0	69.0	61.4	52.0	37.0	30.0	
6.0	66.4	66.1	54.0	48.4	37.0	29.8	21.0
7.0	56.2	55.9	48.3	43.3	36.2	28.5	21.0
8.0	48.5	48.1	43.4	38.8	33.7	27.0	20.0
9.0	42.4	42.1	39.3	35.2	31.0	25.2	19.4
10.0	37.7	37.3	36.0	32.1	28.2	23.4	18.6
12.0		30.0	29.5	27.1	24.4	20.4	16.6
14.0			22.4	22.1	21.1	17.9	14.8
16.0			17.7	17.4	18.3	15.9	13.3
18.0				14.0	14.9	14.3	12.0
20.0					12.3	12.8	10.8
22.0					10.2	10.8	9.8
24.0					8.6	9.1	9.0
26.0						7.8	8.2
28.0						6.7	7.0
30.0						5.7	6.1
32.0							5.3
34.0							4.6
36.0							4.0
38.0							
40.0							
<b>Number of falls</b>	<b>10</b>	<b>8</b>	<b>8</b>	<b>7</b>	<b>5</b>	<b>4</b>	<b>3</b>
I	0 %	33 %	66 %	100 %	100 %	100 %	100 %
II	0 %	0 %	0 %	0 %	33 %	66 %	100 %
III	0 %	0 %	0 %	0 %	33 %	66 %	100 %
The load ratings must be reduced if using a direct-mounted fly boom on main body.							
Load capacity reduction [kg]	600	485	405	350	275	225	195

Table no. 6113 M-75/3700/19.2+0.0/10.18HA0.3°

## Notes:

- The load ratings given apply when the machine is on a firm and level surface ( $\pm 0.3^\circ$ )
- The load ratings are given in tonnes and apply 360 degrees.
- The load capacities correspond to EN13000.
- The weight of the load handling equipment (hooks, suspension gear) should be deducted from the load capacities.
- The load ratings apply for the maximum stabilizer width (7.4 m).
  - Load capacities must be limited or reduced in adverse conditions such as soft or uneven ground, slopes, wind, side loads, swinging loads, jolts or sudden stopping of loads, personnel and operators not experienced in handling loads.
- Permissible cable pull per strand in crane mode for cable diameter 26 mm - 12,500 kg.
- The load ratings given are for reference only. Please refer to the tables in the operating instructions for the relevant applicable load ratings.

# 6113E Load ratings



Main boom HA 40.2 m  
freestanding on wheels Pick & Carry < 3 km/h

	Boom length [m]						
	12.6	15.7	18.9	22.0	28.0	34.0	40.2
<b>Reach [m]</b>							
<b>2.0</b>							
<b>2.5</b>							
<b>3.0</b>	45.0						
<b>4.0</b>	36.6	36.0	35.4	35.1			
<b>5.0</b>	30.5	29.8	29.1	28.9	29.6		
<b>6.0</b>	25.7	25.1	24.5	24.2	25.0		
<b>7.0</b>	22.0	21.4	20.9	20.6	21.4		
<b>8.0</b>	19.1	18.5	18.0	17.7	18.4		
<b>9.0</b>	16.8	16.1	15.7	15.3	16.1		
<b>10.0</b>	14.8	14.2	13.7	13.4	14.1		
<b>11.0</b>		12.5	12.0	11.7	12.5		
<b>12.0</b>		11.1	10.7	10.3	11.1		
<b>13.0</b>		9.8	9.4	9.1	9.9		
<b>14.0</b>			8.3	8.1	8.8		
<b>16.0</b>			6.5	6.2	7.0		
<b>18.0</b>				4.8	5.6		
<b>20.0</b>					4.4		
<b>22.0</b>					3.4		
<b>24.0</b>					2.5		
<b>26.0</b>							
<b>28.0</b>							
<b>30.0</b>							
<b>32.0</b>							
<b>34.0</b>							
<b>Number of falls</b>	<b>10</b>	<b>8</b>	<b>8</b>	<b>7</b>	<b>5</b>	<b>4</b>	<b>3</b>
<b>I</b>	0 %	33 %	66 %	100 %	100 %	100 %	100 %
<b>II</b>	0 %	0 %	0 %	0 %	33 %	66 %	100 %
<b>III</b>	0 %	0 %	0 %	0 %	33 %	66 %	100 %
The load ratings must be reduced if using a direct-mounted fly boom on main body.							
Load capacity reduction [kg]	-	-	-	-	-	-	-

Table no. 6113 M-75/2350/19.2+0.0/10.18HA(0°/180°) (P&C)

## Notes:

- The load ratings given apply for procedures where the load is on a firm and level surface ( $\pm 0.3^\circ$ ).
- The load ratings are given in tonnes and apply to the uppercarriage in direction of travel ( $\pm 10^\circ$ ).
- The load capacities correspond to EN13000.
- The weight of the load handling equipment (hooks, suspension gear) should be deducted from the load capacities.
- Load capacities must be limited or reduced in adverse conditions such as soft or uneven ground, slopes, wind, side loads, swinging loads, jolts or sudden stopping of loads, personnel and operators not experienced in handling loads.
- Permissible cable pull per strand in crane mode for cable diameter 26 mm - 12,500 kg.
- The load ratings given are for reference only. Please refer to the tables in the operating instructions for the relevant applicable load ratings.
- Values marked with \* only apply with special equipment.

8 Technical features and dimensions subject to change.



# 6113E Crane equipment



Heavy-duty jib SLS

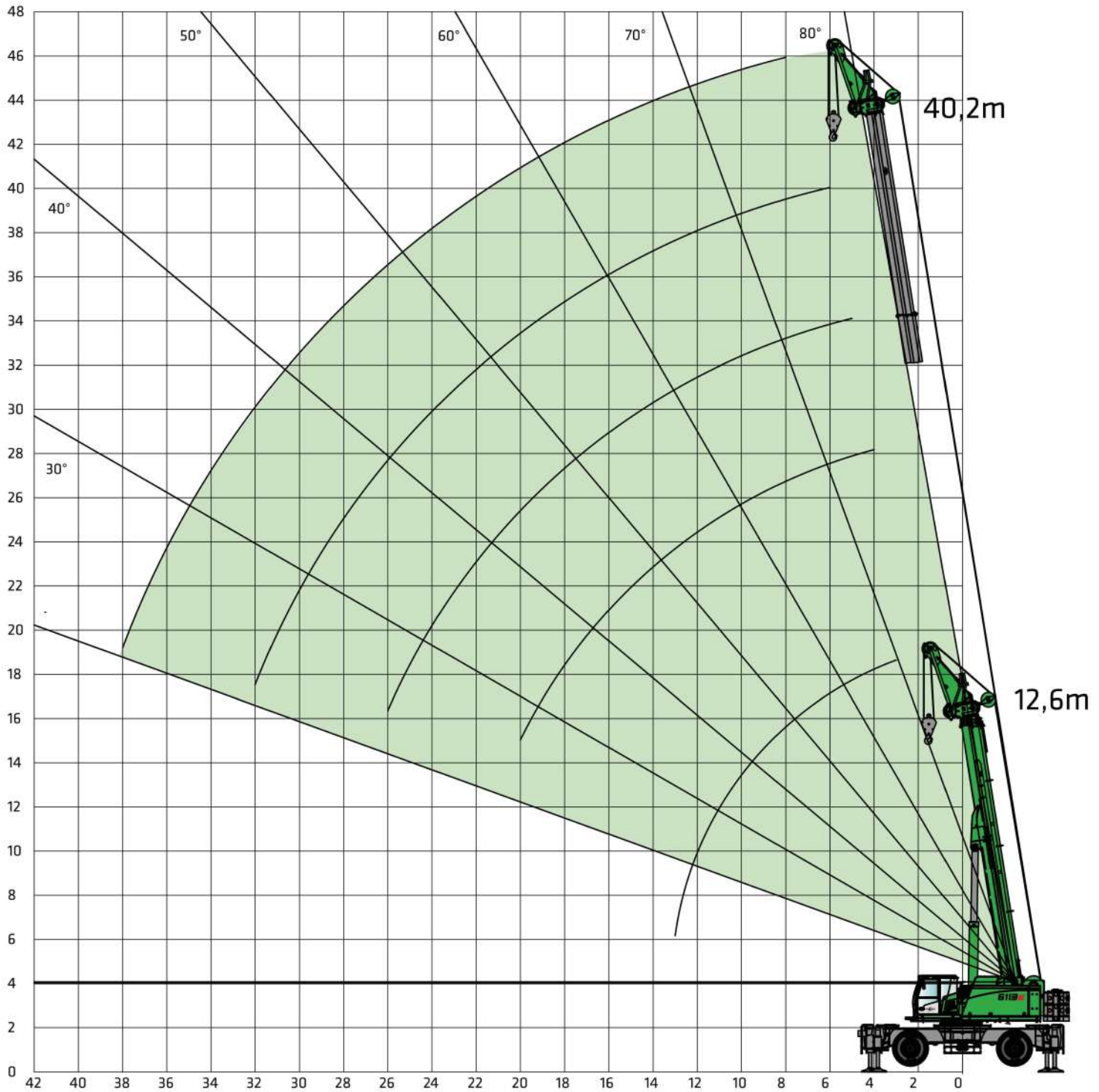

# 6113E Load ratings



Heavy-duty jib SLS  
outrigger-supported 100 %

Reach [m]	Boom length [m]				
	12.6	22.0	28.0	34.0	40.2
2.0					
3.0	36.0				
4.0	35.8	36.0			
5.0	33.6	36.0	26.0		
6.0	31.8	35.1	26.0	26.0	
7.0	30.2	33.6	26.0	24.8	
8.0	28.9	32.4	26.0	23.5	19.2
9.0	27.9	31.3	25.5	22.2	18.2
10.0	27.0	29.6	24.9	20.9	17.1
11.0	26.4	27.6	23.5	19.6	16.0
12.0	26.1	25.6	22.0	18.3	15.1
13.0	25.6	23.7	20.6	17.2	14.4
14.0		22.1	19.4	16.3	13.6
16.0		18.2	17.2	14.5	12.2
18.0		14.8	15.1	13.0	11.0
20.0		12.2	12.5	11.2	9.9
22.0			10.5	10.7	9.0
24.0			8.8	9.2	8.2
26.0			7.5	7.8	7.5
28.0				6.7	6.9
30.0				5.7	6.0
32.0				4.9	5.2
34.0					4.4
36.0					3.8
38.0					3.3
<b>Number of falls</b>	<b>3</b>	<b>3</b>	<b>3</b>	<b>3</b>	<b>3</b>
I	0 %	100 %	100 %	100 %	100 %
II	0 %	0 %	33 %	66 %	100 %
III	0 %	0 %	33 %	66 %	100 %

Table no. 6113M-75/3700/19.2+0.0/10.18SLS 0.3°

## Notes:

- The load ratings given apply when the machine is on a firm and level surface ( $\pm 0.3^\circ$ ).
- The load ratings are given in tonnes and apply 360 degrees.
- The load capacities correspond to EN13000.
- The weight of the load handling equipment (hooks, suspension gear) should be deducted from the load capacities.
- The load ratings apply for the maximum stabilizer width (7.4 m).
- Load capacities must be limited or reduced in adverse conditions such as soft or uneven ground, slopes, wind, side loads, swinging loads, jolts or sudden stopping of loads, personnel and operators not experienced in handling loads.
- Permissible cable pull per strand in crane mode for cable diameter 26 mm - 12,500 kg.
- The load ratings given are for reference only. Please refer to the tables in the operating instructions for the relevant applicable load ratings.

# 6113E Transport dimensions and weights

**Weight: approx. 85.5 t (2 winches, 80 t hook, 19.2 t counter weight)**  
**Transport dimensions: 15.3 m x 4.0 m x 4.05 m**

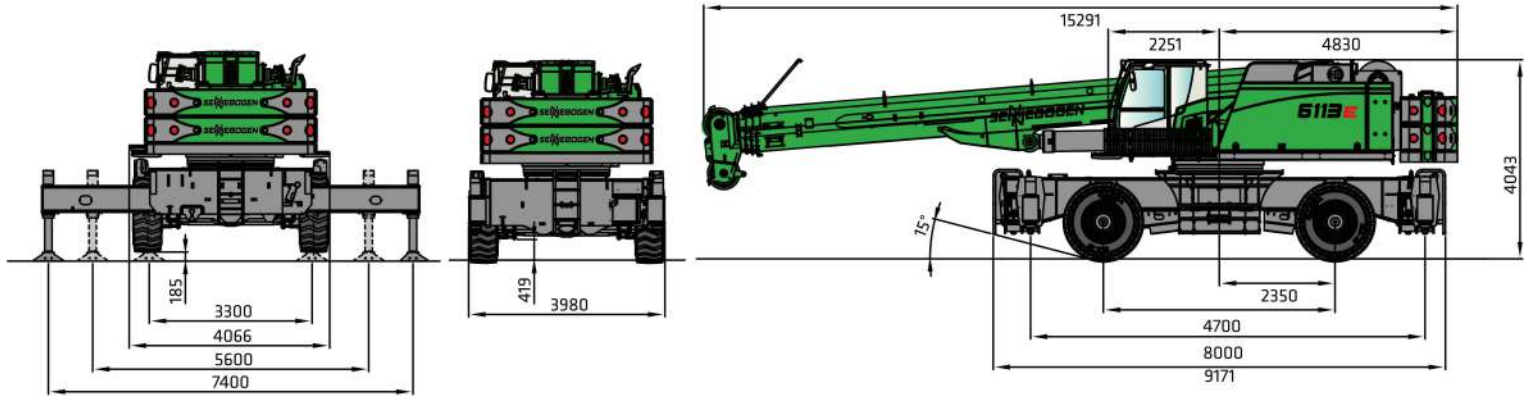

**Weight: approx. 66.3 t (2 winches, 80 t hooks)**  
**Transport dimensions: 15.1 m x 4.0 m x 4.05 m**

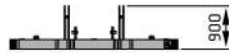
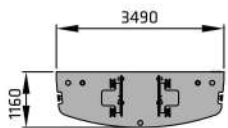
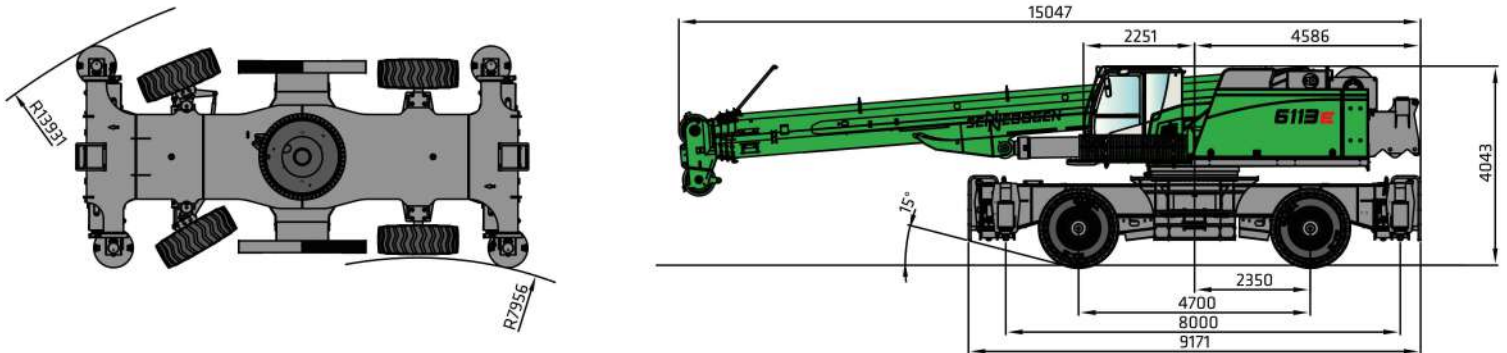

**Ballast base plate**

**1 x**

**5400 kg**

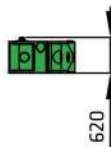
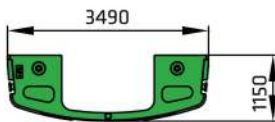

**Ballast plates**

**2 x**

**6980 kg**

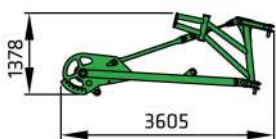

**Heavy-duty jib**

**650 kg**

# 6113E

## M



This catalog describes machine models, scopes of equipment of individual models, and configuration options (standard equipment and optional equipment) of the machines delivered by SENNEBOGEN Maschinenfabrik. Machine illustrations can contain optional equipment and supplemental equipment. Actual equipment may vary in a tolerance range depending on the country to which the machines are delivered, especially in regard to standard and optional equipment.

All product designations used may be trademarks of SENNEBOGEN Maschinenfabrik GmbH or other supplying companies, and any use by third parties for their own purposes may violate the rights of the owners. Please contact your local SENNEBOGEN sales partner for information concerning the equipment variants offered. Requested performance characteristics are only binding if they are expressly stipulated upon conclusion of the contract. Delivery options and technical features are subject to change. Errors and omissions excepted. Equipment is subject to change, and rights of advancement are reserved. © SENNEBOGEN Maschinenfabrik GmbH, Straubing/Germany. Reproduction in whole or in part only with written consent of SENNEBOGEN Maschinenfabrik GmbH, Straubing, Germany.

**SENNEBOGEN**

**SENNEBOGEN**  
**Maschinenfabrik GmbH**  
Sennebogenstraße 10  
94315 Straubing, Germany

Tel. +49 9421 540-144/146  
marketing@sennebogen.de

Item No. / Item No. 299265  
6113-M-E-031901-071975-0919d

GO FOR GREEN

 [www.sennebogen.com](http://www.sennebogen.com)