

MODEL RANGE

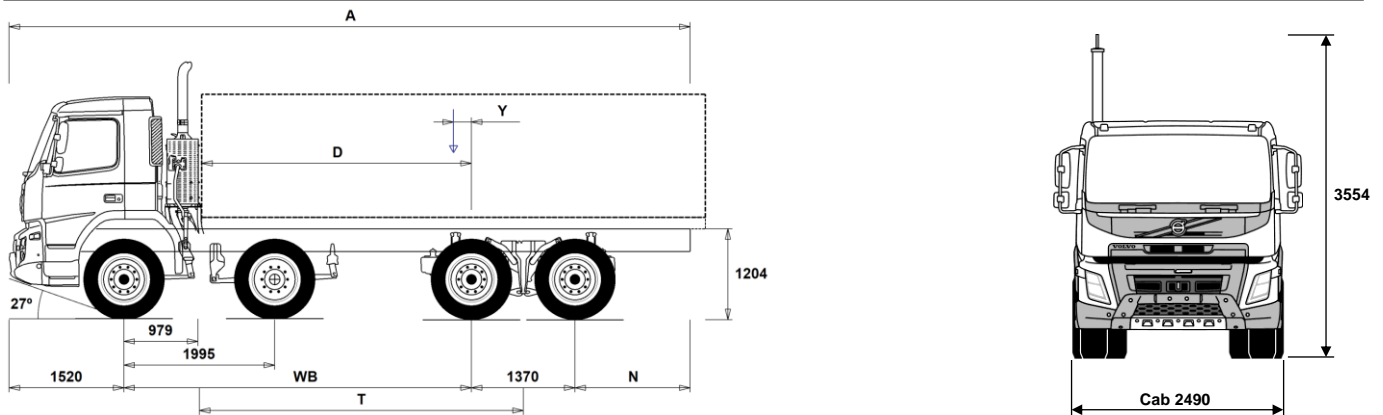

Volvo Trucks. Driving Progress

FMX13 8x6 Rigid - Rear Air Suspension - N3G FM 86F R3CAX



Chassis Dimensions [mm]

WB Wheelbase	4600	4900	5100	5600
A Overall Chassis Length	10015	10465	10815	11565
D Center of rear axle to front of body	3571	3871	4071	4571
N Rear Overhang (Min.)	1225	1225	1225	1225
N Rear Overhang (Max.)	2525	2675	2825	3075
T Theoretical Wheelbase	4288	4588	4788	5288
Y Center of Gravity for Payload (Min.)	39	99	139	237
Y Center of Gravity for Payload (Max.)	1204	1349	1446	1687

Chassis Weights [kg]

Front Axles	7645	7615	7605	7570
Rear Bogie	3250	3330	3390	3500
Kerb Weight	10895	10945	10995	11070
Payload (including body, driver, fuel, etc.)	18955	18905	18855	18780

Turning Diameter [mm]

Turning Circle Diameter Kerb to Kerb	18200	19200	19800	21300
Turning Circle Diameter Wall to Wall	19700	20600	21200	22800

Plated Weights [kg]

	Plated	Design
Gross Vehicle Weight	29850	37000
Gross Combination Weight	44000	60000
Front Axles	16000	16000
Rear Bogie	19000	21000

Important Notes

Chassis Dimensions

Cab Height: +167 mm for CAB-HSLP, +167 mm for CAB-SLP.
 Front Axle to Back of Cab: +506 mm for CAB-HSLP and CAB-SLP.
 D-measure includes a front clearance of 50 mm and for rigid trucks also a subframe of 100 mm.
 Height can vary ± 20 mm for leaf and ± 10 mm for air suspension.
 All dimensions are for unladen chassis and any tag axles down.
 Rear overhang used for vehicle weight calculation is the maximum rear overhang (N Max.) for selected wheelbase.

Weight and dimensions are based upon the following tyres:

Front Axle Tyres:	315/80R22.5
Drive Axle Tyres:	315/80R22.5

Chassis weight includes oil, water, AdBlue, 0 litres fuel and without driver. Kerb weight can vary $\pm 3\%$.

Turning diameters are theoretically calculated.

Legal weights can differ from country to country.

For more detailed weight information, including optional equipment weights, ask your Volvo sales contact to enter your specification into the Volvo Weight Information system (WIS).

Do NOT use this drawing for bodybuilding. Refer to Volvo Bodybuilder Instructions and chassis assembly drawing FM86FR3CAX.

MODEL RANGE

FMX13 8x6 Rigid - Rear Air Suspension - N3G FM 86F R3CAX

TRUCK USE

- **RC-ROUGH** Operating class on/off road
- **TIPP-PRE** Tipper vehicle preparation
- **UNIFORM** Basic platform vehicle

CORE COMPONENTS

- **CHH-XXHI** Chassis height XX High - For a specific loading height always check the unique BEP chassis drawing
- **RADD-G2** Rear air suspension, 2 axles - 2 driven, high ground clearance
- **FMX-DAY** Day cab - with steel safety cage design
Designed and built to Swedish impact and ECE R29 regulations
- **FMX-HSLP** Globetrotter cab - with steel safety cage design
Designed and built to Swedish impact and ECE R29 regulations
- **FMX-SLP** Sleeper cab - with steel safety cage design
Designed and built to Swedish impact and ECE R29 regulations
- **EU6SCR** Emission level - Euro 6
- **D13K420** D13K420 12.8l engine developing 420hp at 14-1800rpm.
Peak torque 2100Nm at 860 -1400rpm.
- **D13K460** D13K460 12.8l engine developing 460hp at 14-1800rpm.
Peak torque 2300Nm at 900-1400rpm.
- **D13K500** D13K500 12.8l engine developing 500hp at 14-1800rpm.
Peak torque 2500Nm at 1000-1400rpm.
- **D13K540** D13K540 12.8l engine developing 540hp at 14-1800rpm.
Peak torque 2600Nm at 1000-1450rpm.
- **EBR-EPG** Exhaust brake controlled by steering column switch
- **EBR-EPGC** Exhaust pressure governor for I shift gearbox
- **EBR-VEB+** Volvo engine brake + and exhaust pressure governor, enhanced performance from additional exhaust rocker control.
Retardation 375kW
- **AT2612F** AT2612F 12-speed "I-shift" automated mechanical gearbox suitable for gross train weights up to 60tonne only refer to sales engineering when used in conjunction with a PTO
- **ATO2612F** ATO2612F 12-speed "I-shift" overdrive automated mechanical gearbox suitable for gross train weights up to 60tonne refer to sales engineering when used in conjunction with a PTO
- **PT2606** Powertronic automatic 6-speed gearbox, max. engine torque 2600 Nm, max. permitted GCW 130000 kg
- **RTH2610F** RTH2610F hub reduction tandem 26tonne drive axles, GCW 100 tonnes with differential and cross locks*
* Cross locks replaced by a dog clutch if tandem axle lift is specified

PACKAGES

- **DRIVEFM** Driving package
- **DRIVEFM+** Driving plus package
- **BEDFM** One bed resting package
- **AUDHIG** High Power Audio system: RDS radio with CD player - also playing MP3/WMA files from CD -, with integrated bluetooth phone and USB/Line inputs. FM/AM antenna, speakers in dashboard, doors, and sleeping compartment.
- **MEDIA** AM/FM Bluetooth radio without CD player.
USB and Aux line inputs.
Speakers in dashboard, doors, and sleeping compartment.
7" touch screen with personal apps.
- **MEDIADF** AM/FM Bluetooth radio without CD player.
USB and Aux line inputs.
Speakers in dashboard, doors, and sleeping compartment.
7" touch screen with personal and professional apps.
Dynafleet vehicle on-board data display with office internet support.
- **MEDIANAV** AM/FM Bluetooth radio without CD player.
USB and Aux line inputs.
Speakers in dashboard, doors, and sleeping compartment.

- Standard Equipment
- Optional Equipment

For more detailed information about cab and powertrain equipment, please refer to separate specification sheets.

For all possible options and combinations of options please consult your Volvo sales contact who can create a specification to match your requirements using the Volvo Sales Support system (VSS).

The factory reserves the right to modify design and change equipment without previous notification.
The specification can vary from country to country.

- **MEDIANDF** 7" touch screen with personal and professional apps.
Truck based satellite navigation (live updates not included)
AM/FM Bluetooth radio without CD player.
USB and Aux line inputs.
Speakers in dashboard, doors, and sleeping compartment.
7" touch screen with personal and professional apps.
Truck based satellite navigation (live updates not included)
Dynafleet vehicle on-board data display with office internet support.
- **CHASSIS**
- **FST-PAR3** Front suspension type - 3 leaf parabolic springs
- **FAL16.0** Front axles design capacity 16 tonnes - 2 x 8.0 tonne front axles
- **FAL18.0** Front axles design capacity 18 tonnes - 2 x 9 tonne front axles - check tyre load index
- **FAL20.0** Front axles design capacity 20 tonnes - 2 x 10.0 tonne front axles - UK weight 17tonnes in use - check tyre load index
- **FSM-LUB** Lubricated rear shackles on front suspension pins and bushings
- **FSTAB** Front anti-roll bar
- **RSLB-BAS** Rear air suspension basic levelling stroke
- **RAL21** Rear bogie design capacity 21 tonnes
- **RAL26** Rear bogie design capacity 26 tonnes
- **RSTAB3** Rear stiff anti-roll bar
- **RALIM105** Rear axle load limiter, 10.5 tonnes
- **RALIM115** Rear axle load limiter, 11.5 tonnes
- **RALIM13** Rear axle load limiter, 13 tonnes
- **RALIM95** Rear axle load limiter, 9.5 tonnes
- **ASF-DL1** Air suspension with 1 driving level
- **ASF-DL3** Air suspension with 3 driving levels
- **PSS-DUAL** Dual power steering system
- **PSP-VAR** Power steering pump with variable displacement
- **EBS-MED** EBS medium package including "hill" hold function
- **AUXPARK** Additional spring parking brakes
- **SUSPL-EC** Remote electronic control on wander-lead for air suspension levelling
- **FRAME300** Frame rail section external height 300 mm
- **FST8080** Frame thickness - web and flange 8.0mm
- **FIL-EEEEB** Inner liner from end of engine to end of bogie
- **FIL-EEEF** Inner liner from end of engine to end of frame
- **FIL-FBEB** Inner liner over rear bogie
- **FIL-FBEF** Inner liner from front of bogie to end of frame
- **FIL-TXEB** Inner liner from gearbox member to end of bogie
- **FIL-TXEF** Inner liner from gearbox member to end of frame
- **BBOX-L** Battery box located on left hand side
- **2BAT210B** 2 x 210 Ah capacity Gel batteries
- **2BATT170** 2 x 170 Ah capacity batteries
- **2BATT225** 2 x 225 Ah capacity batteries
- **BATTAMP** Battery voltage and ampere gauge
- **BATTIND** Battery charge indication
- **MSWI-C** Main switch - Chassis mounted toggle switch by battery box
- **MSWI-R** Main switch - Key fob operated remote controlled
- **R315A56** Right aluminium 560 mm D-shaped fuel tank, 315 litres volume
Min volume 255l
Max volume 630l
- **UL-FUEL** Without left fuel tank
- **ADTP-L** AdBlue tank on left hand side
- **ADTP-LF** AdBlue tank on left hand side at the front
- **ADTP-R** AdBlue tank on right hand side
- **ADB032** AdBlue tank usable volume 32 litres

MODEL RANGE

FMX13 8x6 Rigid - Rear Air Suspension - N3G FM 86F R3CAX

■ FCAP-L	Locking fuel filler cap	■ TOOL-BAS	Basic Toolkit
■ FUFF-AS	Fuel filling anti-spillage device	□ TOOLKIT	Complete tool kit
□ FUFF-ATS	Fuel filling anti-theft and anti-spillage devices	□ INFLAHOS	Tyre inflation hose
□ ESH-REAR	Horizontal silencer, rear exhaust outlet	□ GAUGE-TP	Tyre pressure gauge
□ ESH-VERT	Horizontal silencer, vertical exhaust outlet	□ OBDEP-C	Euro 6 Step C emission level
■ ESHVERT	Horizontal chassis mounted diesel particulate filter and vertical SCR silencer behind cab	□ OBDEP-D	Euro 6 Step D emission level
□ EXST-SSP	Stainless steel exhaust stack - NOT polished	DRIVELINE EQUIPMENT	
■ EXST-ST	Steel exhaust stack	□ ASO-C	Crawler gear - Ratio direct top gearbox 19:1 Ratio Overdrive gearbox 17:1
□ WHC-FIX2	Two fixed wheel chocks	□ ASO-ULC	Ultra low crawler and crawler gear - Ratios direct top gearbox 32:1 and 19:1 Ratios Overdrive box 32:1 and 17:1
□ WHC-FOL2	Two foldable wheel chocks	□ TRAP-HD	Reinforced gearbox application
□ WHCP-F	Wheel chock(s) stored in the front part of the vehicle	□ TP-CON	Construction Package
□ WHCP-R	Wheel chock(s) stored in the rear part of the vehicle	□ TP-DIST	Distribution Package
□ WHCP-T	Transport mounted wheel chock(s) stored in cab outer luggage locker	□ TP-HD	I-shift software - Heavy duty for high GCW Special conditions apply consult Sales Engineering
□ TB-L80	Toolbox 800 mm, left side	□ TP-LONG	Long Haul Package
□ TB-R80	Toolbox 800 mm, right side	□ AMSO-AUT	Enhanced I-shift software with manual shift available in auto mode and kickdown facility on accelerator pedal
□ CHAIN-S	Snow chains	□ AVO-ENH	Enhanced software for off road driveability and starting
□ HOOK-SC	Snow chain hooks	□ APF-ENH	I-shift enhanced PTO functions
■ TOWF-HD1	One heavy duty front towing device	■ CS43B-O	Single plate 430mm (17") clutch
□ TOWMBRH	Towing member, high mounted in centre of frame, D = 190	□ RET-TPT	Hydraulic Retarder for Powertronic gearbox
□ TOWMBRL1	Towing member, low mounted under the frame	□ TC-HWO	Automatic gearbox oil cooler - water to oil
□ TOWMBRM	Towing member, medium mounted in line with frame lower flange	□ TC-MAOH2	Extra high performance transmission oil cooler - air to oil with front mounted radiator
■ RFEC-S	Rear frame end, straight cut for regular platform applications	□ TC-MWO	Basic transmission oil cooler - water to oil
□ RFEC-U	Rear frame end, upper cut for tipper applications.	□ TC-MWOH2	High performance transmission oil cooler - water to oil
□ C-RI4040	Towing coupling, Ringfeder 4040 G-150	□ 2COM1100	Two cylinder, air compressor, 1100 litres per minute
□ C-RI5055	Towing coupling, Ringfeder 5055 G-150	■ 2COMP900	Two cylinder, air compressor, 900 litres per minute
□ C-RO400G	Towing coupling, Rockinger 400 G-150 for 40mm eyes	□ CLU-AIRC	Clutchable air compressor
□ C-RO50	Rockinger RO 50 50mm for centre axle trailer	■ AIRIN-HI	Roof mounted air intake behind cab on left hand side
□ TOWR-ONE	Towing hitch attached to rear crossmember	□ AIRIN-LO	Low level air intake behind cab on left hand side
■ TREL-PK	Trailer electrical preparation kit - chassis/cab wiring	□ ACL1ST-S	Two stage air filter
□ TREL14	Single 14 pole electrical trailer connector	■ 24AL110B	110 amp alternator
□ TREL15	Single 15 pole electrical trailer connector - ADR certified	□ 24AL120B	120 amp alternator
□ TREL7	7 pole - 24N trailer electrical suzie	□ 24AL150B	150 amp alternator
□ TREL7-7	24N and 24S trailer electrical suzies	■ CCV-C	Closed crankcase engine ventilation
□ TBC-DUO	Duomatic type air line connectors	□ CCV-O	Open crankcase engine breather
□ TBC-EC	Palm coupling type air line connectors	□ CCV-OX	Closed crankcase ventilation for cold markets
□ TRBR-HCF	Full pressure hand controlled trailer brake	■ PRIM-EL	Electrical priming pump
■ TRBR-STA	Stationary trailer brake control	□ PRIM-MAN	Manual priming pump
□ RUP-FOSL	Folding & sliding EC approved aluminium rear underrun	□ FUEQ-EH	Fuel line electric heater
□ FFEND-T	Transport mounted mud wings on second front axle	□ AF-R	Hot fuel recirculation heated fuel filter
□ RFEND-B	Three piece EC approved rear mud wings and spray flaps	□ FUEFE2LW	Large engine mounted dual fuel filter with water separator
□ RFEND-T	Rear mud wings, transport mounted	■ FUEFE2SW	Small engine mounted dual fuel filter with water separator
□ RFH-BAS	Basic rear wing height	□ EST-AID	Air inlet manifold starting heater element
□ RFH-HIG	High rear wing height - higher wing tops	□ 220EBH15	220V/1.5Kw electric engine block heater
□ RFH-LOW	Lower rear wing height - shallower wing tops	□ PTER-100	Rear engine mounted power-take-off with DIN 100 / ISO 7646 flange
■ ATANK-ST	Steel air tanks	□ PTER-DIN	Rear engine mounted PTO with DIN5462 (female) splined shaft for a close coupled pump. Models with 3 steering axles will use this to drive the steering pump (AUXPSP)
■ TL-LED	LED Tail lights	□ PTER1400	Rear engine mounted power-take-off with SAE 1410 flange
□ BLIGHT-E	Emergency brake light	□ HPE-F101	Parker F1-101, engine mounted, fixed displacement, single flow, engine mounted hydraulic pump
WHEELS & TYRES		□ HPE-F41	Parker F1-41, engine mounted, fixed displacement, single flow,
□ RT-SPOKE	Spoke rims on all axles		
■ RT-STEEL	Steel rims on all axles		
□ SPWT-D	Spare wheel & tyre with rear tyre pattern		
□ SPWT-F	Spare wheel & tyre with front tyre pattern		
□ SWCP-T	Spare wheel supplied temporarily strapped to chassis		
□ SWCP-TP	Temporary spare wheel carrier on top of chassis frame		
□ JACK-20T	20 tonne bottle jack		

■ Standard Equipment

□ Optional Equipment

For more detailed information about cab and powertrain equipment, please refer to separate specification sheets.

For all possible options and combinations of options please consult your Volvo sales contact who can create a specification to match your requirements using the Volvo Sales Support system (VSS).

The factory reserves the right to modify design and change equipment without previous notification. The specification can vary from country to country.

MODEL RANGE

FMX13 8x6 Rigid - Rear Air Suspension - N3G FM 86F R3CAX

- HPE-F51** engine mounted hydraulic pump
Parker F1-51, engine mounted, fixed displacement, single flow, engine mounted hydraulic pump
- HPE-F61** Parker F1-61, engine mounted, fixed displacement, single flow, engine mounted hydraulic pump
- HPE-F81** Parker F1-81, engine mounted, fixed displacement, single flow, engine mounted hydraulic pump
- HPE-T53** Parker F2-53/53, engine mounted, Fixed displacement, Twin flow engine mounted hydraulic pump
- HPE-T70** Parker F2-70/35, engine mounted, Fixed displacement, Twin flow engine mounted hydraulic pump
- HPE-V45** Parker VP1-45, variable displacement, single flow, engine mounted hydraulic pump
- HPE-V75** Parker VP1-75, variable displacement, single flow, engine mounted hydraulic pump
- PTPT-D** Powertronic PTO, 1 front/upper DIN connection for plug-in pump (max. 850 Nm)
- PTPT-F** Powertronic PTO, 1 front/upper rear facing SAE flange conn. for prop shaft (max.850 Nm)
- PTR-D** Gearbox PTO for plug-in pump, 0.71xeng speed
- PTR-DH** Gearbox driven high speed PTO for one plug-in hydraulic pump
- PTR-DM** Gearbox driven medium speed PTO for one plug-in hydraulic pump
- PTR-F** Gearbox driven PTO with rear flange connection
- PTRD-D** Gearbox driven HIGH SPEED PTO for two plug-in hydraulic pumps
- PTRD-F** PTO with 1 DIN + 1 flange connection rear, manual gearbox
- HPG-F101** Parker F1-101 gearbox mounted, fixed displacement, single flow, hydraulic pump
- HPG-F41** Parker F1-41 gearbox mounted, fixed displacement, single flow, hydraulic pump
- HPG-F51** Parker F1-51 gearbox mounted, fixed displacement, single flow, hydraulic pump
- HPG-F61** Parker F1-61 gearbox mounted, fixed displacement, single flow, hydraulic pump
- HPG-F81** Parker F1-81 gearbox mounted, fixed displacement, single flow, hydraulic pump
- EIDLESD** Engine idle shut down
- STWPOS-L** LEFT HAND DRIVE
- STWPOS-R** RIGHT HAND DRIVE
- STWM-LE** Leather steering wheel
- STGW-AD2** Adjustable steering wheel with neck tilt
- STGW-ADJ** Adjustable steering wheel
- AIRBAG** SRS Driver's air bag
- DRC-AMII** DPF Regeneration control switch - for manual and switching off regeneration
- 1DAYDIG** Continental VDO DTCO 3.0 digital tachograph
This tachograph can ONLY offer remote download if the option of Dynafleet or an FMS gateway has been specified with this order.
- 1DAYDIG2** Continental VDO DTCO 4.0 smart tachograph
This tachograph can ONLY offer remote download if the option of Dynafleet or an FMS gateway has been specified with this order.
- 1DAYDIGP** Continental VDO DTCO 3.0 digital tachograph
For vehicles with long lead time - this includes prep kit for the retrofit of DTCO 4.0 tachograph.
For updating to new legal demand for truck registration from 15th June 2019.
This tachograph can ONLY offer remote download if the option of Dynafleet or an FMS gateway has been specified with this order.
- ARSL** Additional road speed limit - switch in dashboard
- CRUIS-E** Eco cruise control (with eco-roll and I-cruise, controls in steering wheel)
- CRUISEC** Cruise control, standard
- RSENS-W** Rain sensing windscreen wipers
- CU-ECC** Electrically controlled air conditioning with sun sensor
- CU-ECC2** Electrically controlled air conditioning with sun sensor, mist sensor, air quality sensor and carbon filter
- CU-MCC** Climate unit with manual controlled air conditioning
- IMMOBIL** Thatcham H2 approved immobiliser
- ALARM-B** Thatcham H1 approved vehicle alarm - Cab only
- ALARM-E** Enhanced vehicle alarm - Thatcham H1 approved - Cab plus external sensor for body/trailer
- ALCOLOCK** Alcolock
- PHONE-PK** Telephone preparation kit (antenna, antenna attachm. cable incl.)
- WLIFT-AD** Electrical window lift, automatic up/down driver side
- WLIFT-EB** Electrical window lift
- WLIFT-ME** Mechanical window lift
- ISUNS-BS** Side interior sun visor on both sides
- ISUNS-DS** Driver's side interior sun visor
- ISUNF-B** Interior front sun visor without mirror
- ISUNF-MD** Interior front sun visor with mirror on driver side
- ISUNF-RE** Electrically operated textile interior sun blind
- ISUNF-RM** Manually operated textile interior sun blind
- CSPU-S** One open storage (behind push open lid) in upper part of dash panel center section
- ADFS** Two extra DIN slots in front shelf - can be fitted with card or drawer available as an accessory
- BUPALARM** Reverse alarm
- BUPMON** Back up monitor with built in 7" screen on dash and one colour camera supplied loose for fitment by bodybuilder.
- RTOLL-PK** Road toll PREPARATION kit for trucks operating with "Toll Collect" in Germany
- LOADIND** Load indicator with central dashboard display
- REMC-MF** Multi-function wireless remote control
- FIREXT3S** 3kg fire extinguisher mounted on seat base
- WARNVEST** High visibility warning vest - no sleeves
- AIDKIT** First aid kit
- AIDKIT1B** First aid kit
- WARNLAMP** Portable warning lamp
- LAMP-IN** Inspection lamp
- BULBKIT** Bulb and fuse kit
- WRITEPAD** Writing pad
- UPHTRI10** Seats: Black embossed textile insert with light grey sides, black vinyl side bolster with blue vinyl side insert.
Interior trim: Raven black bunk and curtains & blue textile side walls
- UPHTRI11** Seats: Light grey embossed textile insert, black raven metallic vinyl bolster with red vinyl side insert.
Interior trim: Raven black bunk and curtains & grey vinyl side walls
- UPHTRI12** Seats: Blue soft textile insert, black vinyl bolster.
Interior trim: Raven black bunk and curtains & blue textile side walls
- UPHTRI13** Seats: Dark grey leather insert and black leather bolster.
Interior trim: Raven black bunk and curtains & grey vinyl side walls
- UPHTRI14** Seat: Dark grey leather insert and black leather bolster.
Interior trim: Raven black bunk and curtains & blue textile side walls
- DST-CF4** Driver seat, comfort, suspended, belt in seat
- DST-CF5** Driver seat, comfort, suspended, belt in seat, electrically heated

Standard Equipment

Optional Equipment

For more detailed information about cab and powertrain equipment, please refer to separate specification sheets.

For all possible options and combinations of options please consult your Volvo sales contact who can create a specification to match your requirements using the Volvo Sales Support system (VSS).

The factory reserves the right to modify design and change equipment without previous notification. The specification can vary from country to country.

MODEL RANGE

FMX13 8x6 Rigid - Rear Air Suspension - N3G FM 86F R3CAX

- DST-CF6** Driver seat, comfort, suspended, belt in seat, electrically heated, ventilated
- SBD-RED** Red seat belts
- SBPRE-DS** Driver seat belt pretensioner
- PST-BAS1** Passenger seat - Fixed non suspended fold up with seatbelt mounted in cab
- PST-BENC** Bench passenger seat
- PST-CF4** Passenger seat - Comfort suspended with seatbelt mounted in seat
- PST-CF5** Passenger seat - Comfort suspended & heated with seatbelt mounted in seat
- PST-STD2** Passenger seat - Fixed non suspended with seatbelt mounted in cab
- PST-STD4** Passenger seat - Standard suspended with seatbelt mounted in cab
- SBPRE-PS** Passenger seat belt pretensioner
- ARM-DBPS** Two armrests on driver seat and one (outer) on passenger seat
- ARMRE-BB** Two armrests on both driver and passenger seat.
- ARMRE-DB** Two armrests, on driver seat only
- ARMRE-PB** Two armrests, on passenger seat only
- ARMRE-PS** Single armrest (next to driver) on passenger seat
- ARU-BAS** Vinyl upholstered armrest
- ARU-LEA** Leather upholstered armrest
- FMAT-RU2** Rubber floor mats, extended
- FMAT-RUB** Rubber floor mats
- FMAT-T2E**
- FMAT-TX2** Textile and rubber floor mats
- LBK-RES** Foldable rest bunk
- LBK70** Lower bunk 700 x2000 mm, fixed
- ULBK** Without lower bunk
- MATL-FI** Firm lower bunk pocket sprung mattress
- MATL-SF** Lower flexizone mattress - semi-firm, pocket springs up to 100kg - 16 stone
- MATL-SO** Lower flexizone mattress - soft, pocket springs up to 85kg - 13.5 stone
- OLMAT-BA** 35mm mattress overlay protector
- OLMAT-PR** 50mm premium mattress overlay protector
- TBK60F** Fixed foldable top bunk 600 x 1900mm
- TBK70F** Fixed foldable top bunk 700 x 1900mm
- PH-CAB2** 1.8kW Air to air night heater
- PH-ENGCA** Engine and cab night heater
- PH-SS** Short stop heater
- SLCP-BAS** Basic sleeper control panel - includes interior light, parking heater, roof hatch and door lock
- SAFE** Safe box for driver's personal items
- ETSB-F** Storage on engine tunnel - on front top
- ETSB-FR** Storage on engine tunnel - on front top and at rear cab wall
- ETSB-FRS** Storage on engine tunnel - on front top & at rear cab wall & storage recessed into tunnel on right hand side
- ETSB-FS** Storage on engine tunnel - on front top and storage recessed into tunnel on right hand side
- ETSB-R** Storage on engine tunnel - box at rear cab wall
- ETSB-RS** Storage on engine tunnel - at rear cab wall and storage recessed into tunnel on right hand side
- ETSB-S** Storage on engine tunnel - recessed into tunnel on right hand side
- RUS-BAS** Rear cab upper storage 154 litres - 300 mm high
- RUS-HIG** Rear cab upper storage 245 litres - 440 mm high
- TABLE** Folding and height adjustable table - on lower bunk
- REF-ICPK** Refrigerator preparation kit, engine tunnel mounted
- BOTH-D** One bottle holder under dashboard centre section
- COFMA-PK** Coffee maker, preparation kit.
- INLI-BAS** Basic white interior lights
- INLI-NL** Interior white and red night light with no dimmer
- INLI-NLD** Interior white and red night light with dimmer function
- ARL-FLEX** Two flexible reading lamps (snake lamps)
- RH-EE** Without roof hatch
- RH-ETR** Roof & escape hatch - Electrically operated, tinted glass with rear opening
- RH-MSR** Steel roof hatch - Manually operated with rear opening
- RH-MTR** Roof & escape hatch - Manually operated, tinted glass with rear opening
- URH** Without roof hatch
- SWIND-BS** Extra side window on both sides behind "B" pillar
- SWIND-PS** Rear side window, passenger side
- VANMIR** Vanity mirror in front shelf
- AS-FUS** Extra shelf in front upper storage compartments
- INFOT-PK** Preparation kit for the mounting of a flat screen TV in cab above the driver's door, includes bracket, electrical and speaker connections

CAB EXTERIOR

- PAICS-B** Basic cab paint - mirrors, sunvisor, instep and bumper supplied in natural finish - grey
- GLAS-TIN** Tinted windows.
- AWIND-RF** Rear window
- DGLAS-L** Laminated door glass
- LOCK-MAN** Manual door locking
- LOCK-MRP** Manual door locking with internal remote control (from driver side) of passenger door
- LOCK-REM** Central locking with remote control
- BUMP-HD** Heavy duty front bumper
- AUXFS** Lower swinging cab step
- GUARD-EH** Engine guard to protect sump and engine hoses
- BUGNET** Insect screen in front of radiator
- CTILT-P-E** Electrically operated hydraulic cab tilt
- CTILT-P-M** Manually operated hydraulic cab tilt
- FCABS-A** Front cab - Air suspension
- FCABS-M** Front cab - Mechanical spring suspension
- RCABS-A** Rear cab suspension - Air
- RCABS-M** Rear cab suspension - Mechanical spring
- MIRCOMFX** Electrically heated and operated exterior mirrors with wide angle mirror on both sides and kerb view mirror on passenger side
- MIRSTDX** Electrically heated exterior mirrors with wide angle mirror on both sides and kerb view mirror on passenger side
- AMIR-F20** Auxiliary front view mirror with a 200mm radius
- SUNV-H** External smoke grey sunvisor
- AD-ROOF** Roof air deflector
- AD-SIDEL** Side air deflector extension panels
- AD-SIDES** Short cab side air deflector for rigid bodywork
- HL-BAS2** Halogen H1 head lamps
- HL-BASIC** Halogen H7 head lamps
- HL-BHID2** Dynamic high intensity Bi-Xenon head lamps
These follow the steering movement and direction of the truck
- HL-CLEAN** Head lamp cleaner - washer jets
- HLP-ST** Headlamp protection
- HL-ADJ** Adjustable headlights with switch in the cab
- ASL-RF2** Two Hella H11 70W spotlamps in sign box - only available with the basic headlight and no lower driving lights.
- ASL-RFPK** Preparation kit for two spotlamps in sign box

Standard Equipment

Optional Equipment

For more detailed information about cab and powertrain equipment, please refer to separate specification sheets.

For all possible options and combinations of options please consult your Volvo sales contact who can create a specification to match your requirements using the Volvo Sales Support system (VSS).

The factory reserves the right to modify design and change equipment without previous notification. The specification can vary from country to country.

MODEL RANGE

FMX13 8x6 Rigid - Rear Air Suspension - N3G FM 86F R3CAX

- **BEACOA2F** Two front roof mounted amber beacon rotating warning lamps
- **BEACOA2R** Two rear roof mounted (on accessory bracket) amber beacon flashing warning LED lamps
- **BEACON-P** Roof beacon wire preparation
- **BEACONA4** Four roof mounted (2 front/2 rear) amber beacon rotating warning lamps

- **CABPT-R1** Single outlet for roof mounted accessories
- **CABPT-R2** Twin outlets for roof mounted accessories.

- **SPOTP-F** Spotlamp preparation in front, max 280W
- **SPOTP-R** Spotlamp preparation on roof, max 280W
- **SPOTP-RF** Spotlamp preparation on cab roof and in cab front, max 2x280W

- **CSGN-FMX** "Volvo FMX" headboard logo
- **HORN-F1S** Single tone Jericho air horn chassis mounted
- **HORN-R2S** Two roof mounted air horns

- **ANT-CBR** Roof mounted antenna for CB radio, single aerial

- **ACCB-R-AP** Front, middle & rear roof mounted accessory brackets
- **ACCB-R-F** Front roof mounted accessory bracket
- **ACCB-R-FM** Front & middle roof mounted accessory brackets
- **ACCB-R-FR** Front & rear roof mounted accessory brackets
- **ACCB-R-M** Middle roof mounted accessory bracket
- **ACCB-R-R** Rear roof mounted accessory bracket
- **ACCB-R-RM** Rear & middle roof mounted accessory brackets

- **REFS-TW** White cab conspicuity markings by packed in cab
- **REFS-TY** Yellow cab conspicuity markings by packed in cab

SUPERSTRUCTURE PREPARATIONS

- **SRWL-PK** Wiring preparation for side & rear work/reverse lamps on side of chassis and a three-position switch, maximum 280W
- **SWL-2FW** Two H3 70W white front chassis mounted (LH/RH side) working lamps and a 2-position switch (On/Off)
- **SWL-2RW** Two H3 70W white rear chassis mounted (LH/RH side) working lamps and a 2-position switch (On/Off)
- **SWL-4W** 4 H3 70W white front (2) & rear (2) chassis mtd (LH/RH side) working lamps & 2-pos switch (On/Off)
- **SWL-PK** Wiring preparation for side work/reverse lamps on side of chassis and a three-position switch, maximum 280W

- **WLC-H2A** Two H3/70W working lamps with amber coloured lens high mounted back of cab
- **WLC-H2W** Two H3/70W white working lamps high mounted on the back of cab
- **WLC-PKCH** Preparation kit (cables and switch) for cab mounted chassis working lamp
- **WLC-PKH** Preparation kit, cables and switch for high mounted working lamps back of cab
- **WLC-PKL** Preparation kit, cables and switch for low mounted working lamps back of cab
- **WLC-PKLH** Preparation kit - cables and switch for low and high mounted working lamps back of cab.

- **ECBB-BAS** Body builder electrical centre without body builder module
- **ECBB-HIG** Body builder electrical centre with body builder module

- **BBCHAS1** One 7-pole connector for Body builder interface
- **BBCHAS3** Three 7-pole connectors for Body builder interface

- **BEPR-T2** Body builder electrical software preparation for tipper with remote control

- **TD-BAS** Trailer detection WITHOUT LED sensing
- **TD-LED** Trailer detection with LED sensing

- **FBA-BTF** Lower front body attachments for torsionally flexible - platform body
- **FBA-BTSF** Lower front body attachments for torsionally semi-flexible body - box or curtainsider

- **HBA-FSFB** Holes for body attachments - flexible/semi-flexible body
- **HBA-SB** Holes for body attachments - stiff body

- **RBA-T2** Lower rear body attachments for helper frame
- **AUXL-SPK** Electrical preparation kit - wiring and switch for snow plough

- lights
- **TAILPRE2** Tail lift preparation kit, wireless remote operation
- **TAILPREP** Taillift preparation kit - cab switch and warning in driver display
- **AESW2** Two Body builder bistable electrical switches (marked AUX1 / AUX2)
- **AESW2PK** 2 Body builder bistable el.switches (marked AUX1/AUX2) and prep. for 4 more switches
- **AUXSW-4** Wiring for 4 extra switches (from Body builder electrical centre to switch positions)

DELIVERY SERVICES

- **TGW-3GWL** Telematics gateway with GSM/GPRS/3G modem and wireless lan WLAN
- **FMS-PK** Fleet Management System gateway
- **DRUT** "My Truck App" Two years subscription to driver utility application

VOLVO

Volvo Truck Corporation

volvotrucks.com