

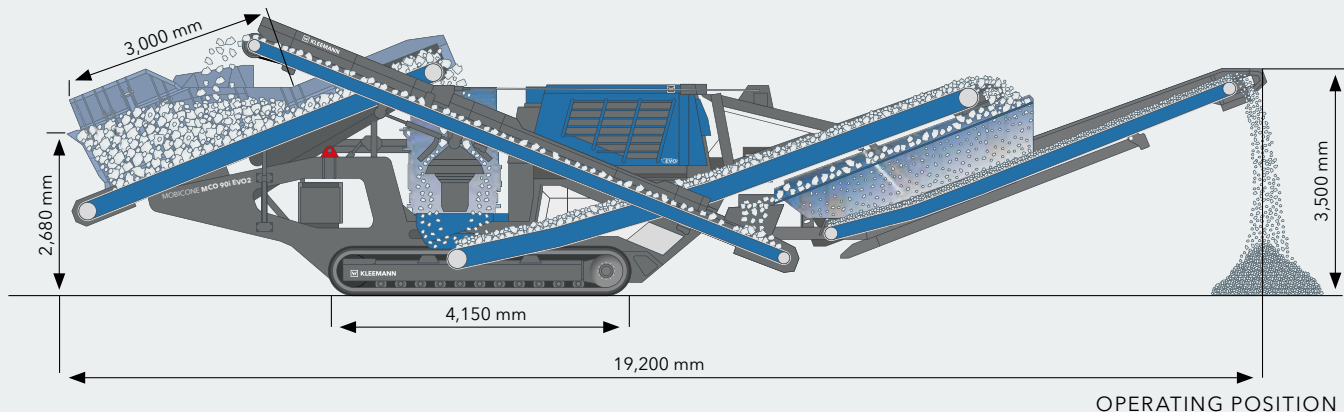

TECHNICAL INFORMATION | TRACK-MOUNTED CONE CRUSHERS

MOBICONE MCO 90(i) EVO2





TECHNICAL HIGHLIGHTS

- Base-mounted cone crusher with large stroke for high crushing capacity and top product quality
- Continuous Feed System (CFS) for optimum crusher loading
- Innovative overload systems for maximum machine availability
- Efficient and powerful diesel-direct drive with load-dependent fan
- Simple and intuitive SPECTIVE control concept
- Linkage option with other KLEEMANN plants (option)

TECHNICAL INFORMATION MC 90(i) EVO2

Feeding unit

Feed capacity up to approx. (t/h) ¹⁾	270
Max. feed size (mm)	200
Feed height approx. (mm)	2,680
Feed height with extension approx. (mm)	3,240
Hopper volume approx. (m ³)	6.6
Hopper volume with extension approx. (m ³)	8.3
Width x length approx. (mm)	2,780 x 3,000
Width x length with extension approx. (mm)	3,700 x 3,500

Feeding conveyor

Width x length (mm)	1,000 x 6,400
---------------------	---------------

Crusher

Cone crusher type	KX 250
Crusher system size d= (mm)	970
Crusher weight approx. (kg)	8,900
Crusher drive type, approx. (kW)	direct, 185
Plant performance at 0-32 mm approx. (t/h)	190 - 220
Plant performance at 0-63 mm approx. (t/h)	245 - 270

Crusher discharge conveyor

Width x length (mm)	800 x 9,100
Discharge height approx. (mm)	3,300

Power supply unit

Drive concept	diesel-direct ²⁾
Drive output of Scania diesel engine (kW)	287 - 289 ³⁾
Generator (kVA)	88 (135 ⁴⁾)

Secondary screening unit (optional)

Type	Vibrating single-deck screen
Width x length (mm)	1,350 x 4,000
Return conveyor approx. (mm)	500 x 9,000
Discharge height of fine grain discharge conveyor approx. (mm)	3,500

Transport dimensions without secondary screening unit

Transport length approx. (mm)	16,050
Transport weight of screening unit approx. (kg) ⁵⁾	6,100
Transport weight basic system - max. equipment approx. (kg)	34,000 - 37,000

Transport dimensions with secondary screening unit

Transport length with screening unit approx. (mm)	20,200
Transport width approx. (mm)	3,240
Transport height approx. (mm)	3,400
Transport weight basic system - max. equipment approx. (kg)	43,500 - 46,500

¹⁾ closed circuit

²⁾ all ancillary drives electric

³⁾ depending on the respective exhaust emission standard

⁴⁾ generator for secondary screening unit (option)

⁵⁾ e.g. as hook lift system



MOBICONE MCO 90(i) EVO2

The MOBICONE MCO 90(i) EVO2 stands out as a powerful team player in hard stone in the 2nd and 3rd crushing stages. Whereas top product quality can be expected from a cone crusher, the MCO 90(i) EVO2 adds an even higher production output to this. With different tools and without further conversion work on the crusher, the cone crusher covers a gap range of 6 - 45 mm - for an even larger range of applications. The plant is characterised by top economy, simple operation and innovative overload systems.

STANDARD EQUIPMENT

- Hopper made of KRS (KLEEMANN Resistant Steel), hopper volume approx. 6.6 m³
- Frequency-controlled feeding conveyor, automatic control depending on crusher level thanks to CFS (Continuous Feed System)
- Metal detector under the feeding conveyor to protect the cone crusher against uncrushable metallic material
- Mechanical overload system in crusher for opening the crushing chamber if unbreakable material enters
- Intelligent overload detection ("Ringbounce Detection") protects the crusher against damage; two modes available
- Wear indicator for recording the current wear level on the crushing tool
- SPECTIVE control concept: menu-prompted user interface, 12-inch operator panel, lockable operating mode selector switch, dust- and vibration-protected; WITOS FleetView telematics system for efficient Fleet and Service Management
- SPECTIVE remote control: wired and radio remote control for the complete set-up procedure from the ground
- Water spray system for reducing dust
- Well-thought-out lighting concept for safe plant operation

OPTIONS

- SPECTIVE CONNECT for displaying all important machine information directly on the smartphone
- Hopper extension up to total hopper volume of 8.3 m³
- Hopper filling aids for rearward loading: width of feed opening 3,700 mm
- Magnetic remover for lifting out magnetic elements
- Diesel refuelling pump: hose system incl. pump, refuelling from a separate tank possible
- Camera system for monitoring the feeding unit and the crusher from the ground, available with additional radio extension
- Small radio remote control with the most important operating functions
- Extended crusher discharge conveyor, can be folded hydraulically
- Crusher discharge conveyor belt cover (standard and extended) and fine grain conveyor
- Head scraper at crusher discharge conveyor and fine grain conveyor
- Belt scales in crusher discharge conveyor and fine grain conveyor
- Secondary screening unit with oversize grain returning for production of defined final grain
- Swivelling return conveyor for operation in closed circuit or with swung-out return and side discharge of oversize grain
- Climate packages: heat and cold package
- Sockets for supplying electrical consumers: 16 A: 230 V / 400 V; 32 A: 400 V;
- Water pump with pressure monitoring
- Increased engine air intake for lower dust load
- Line coupling for interlinking with other KLEEMANN plants
- Additional lockable storage container
- Premium lighting for expanded illumination of work areas



SPARE PARTS

Economic operation of the machine also requires the selection of the correct wear parts. The KLEEMANN original parts are optimally designed to meet the requirements of users and the machine and are characterised by a long service life, superior quality, high availability and simple assembly. Thanks to our application know-how and expertise and competent advice, we help our customers to find the optimal wear part for their individual application.

APPLICATION-SPECIFIC WEAR PARTS

<p>Crusher cone</p>	<p>Versions:</p> <ul style="list-style-type: none"> ☑ Standard ☑ Short Head 						
<p>Bowl liner</p>	<p>Versions:</p> <ul style="list-style-type: none"> ☑ Standard Fine ☑ Standard Medium ☑ Standard Coarse ☑ Short Head Fine ☑ Short Head Medium ☑ Short Head Coarse <p>Two qualities available: > XPERT with 18 % manganese > XTRA with 20 % manganese</p>						
	<table border="0" style="width: 100%; text-align: center;"> <tr> <td data-bbox="247 1256 662 1512"> <p>Standard Coarse (SC)</p> <p>179 - 192 mm</p> <p>25 - 38 mm</p> </td> <td data-bbox="662 1256 1077 1512"> <p>Standard Medium (SM)</p> <p>138 - 157 mm</p> <p>19 - 38 mm</p> </td> <td data-bbox="1077 1256 1535 1512"> <p>Standard Fine (SF)</p> <p>116 - 131 mm</p> <p>16 - 32 mm</p> </td> </tr> <tr> <td data-bbox="247 1563 662 1818"> <p>Short Head Coarse (SHC)</p> <p>130 - 142 mm</p> <p>13 - 25 mm</p> </td> <td data-bbox="662 1563 1077 1818"> <p>Short Head Medium (SHM)</p> <p>99 - 111 mm</p> <p>10 - 22 mm</p> </td> <td data-bbox="1077 1563 1535 1818"> <p>Short Head Fine (SHF)</p> <p>71 - 80 mm</p> <p>10 - 19 mm</p> </td> </tr> </table>	<p>Standard Coarse (SC)</p> <p>179 - 192 mm</p> <p>25 - 38 mm</p>	<p>Standard Medium (SM)</p> <p>138 - 157 mm</p> <p>19 - 38 mm</p>	<p>Standard Fine (SF)</p> <p>116 - 131 mm</p> <p>16 - 32 mm</p>	<p>Short Head Coarse (SHC)</p> <p>130 - 142 mm</p> <p>13 - 25 mm</p>	<p>Short Head Medium (SHM)</p> <p>99 - 111 mm</p> <p>10 - 22 mm</p>	<p>Short Head Fine (SHF)</p> <p>71 - 80 mm</p> <p>10 - 19 mm</p>
<p>Standard Coarse (SC)</p> <p>179 - 192 mm</p> <p>25 - 38 mm</p>	<p>Standard Medium (SM)</p> <p>138 - 157 mm</p> <p>19 - 38 mm</p>	<p>Standard Fine (SF)</p> <p>116 - 131 mm</p> <p>16 - 32 mm</p>					
<p>Short Head Coarse (SHC)</p> <p>130 - 142 mm</p> <p>13 - 25 mm</p>	<p>Short Head Medium (SHM)</p> <p>99 - 111 mm</p> <p>10 - 22 mm</p>	<p>Short Head Fine (SHF)</p> <p>71 - 80 mm</p> <p>10 - 19 mm</p>					