

Submersible drainage pump

P 801

P 801 W

50 Hz

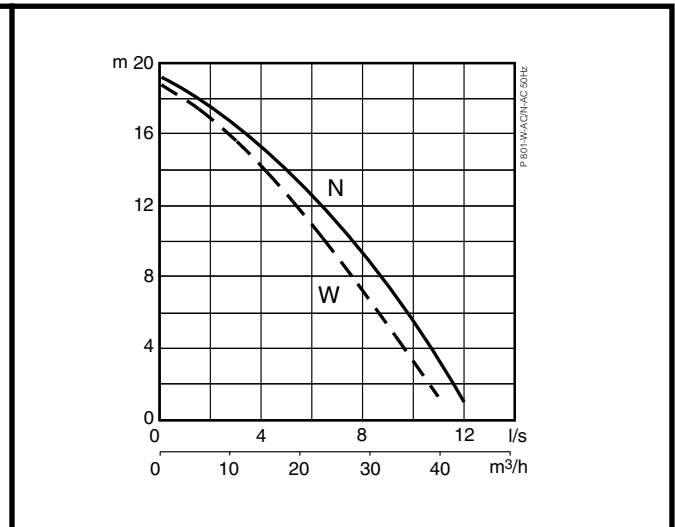
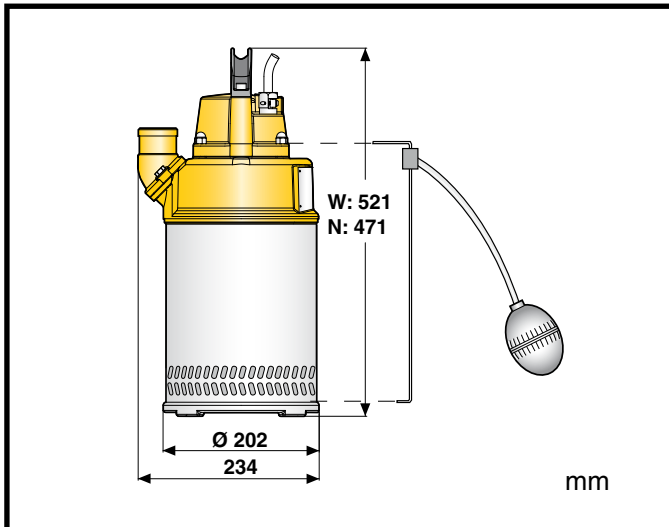

Specification

Electric submersible pump.
 Maximum submergence: 20 m. Protection class IP 68.
 Max temperature of pumped medium at max power input and continuous duty 40°C.
 Max medium density 1100 kg/m³
 pH of the pumped medium 5-8.
 Strainer hole 6.5 x 15.5 mm. Max number of starts 30/hour.

Pump Types

P 801 W/WA* Medium head, single-phase
 P 801 N/NA* Medium head, 3-phase

*option: built in float switch excl. 500 V

Electric Motor

Single-phase induction motor with built-in start and run capacitor, 50Hz.
 Service factor 1.1. Class F insulation.
 Max. power input P₁: 1.9 kW. Motor rating P₂: 1.4 kW.
 Speed: 2800 rpm

Voltage, V	230
Nominal current, A	8.1

3-phase squirrel-cage induction motor, 50Hz.
 Service factor 1.1. Class F insulation.
 Max. power input P₁: 1.8 kW. Motor rating P₂: 1.4 kW.
 Speed: 2800 rpm
 D.O.L. start with built-in contactor

Voltage, V	230	400	500
Nominal current, A	5.0	2.9	2.3

Power Cable

20 m type S1BN8-F:
 4 x 1.5 sq.mm. (3-phase)
 3 x 1.5 sq.mm. (single-phase)

Motor Protection

Built-in thermal switches in the stator winding (140°C, ±5).

Shaft Seal

Double mechanical seal in oil bath.

Primary seal: Silicon carbide on silicon carbide
 Secondary seal: Silicon carbide on silicon carbide

Bearings

Upper bearing: Single-row deep groove ball bearing
 Lower bearing: Single-row deep groove ball bearing

Materials

	EN	ASTM
Castings:	Aluminium EN 1706: AC-43100	ASTM AISi10mg
Casing / Fasteners:	Stainless steel 10088: X5CrNi18-10 (1.4301)	AISI 304
Shaft:	Stainless steel 10088: X20Cr13 (1.4021)	AISI 420
Impeller:	White cast iron EN-GJN-HV600 (XCr23)	ASTM A 532: Alloy III A
Wear parts / O-rings:	Nitrile rubber	

Discharge Connections

1 1/2", 2" (standard), 2 1/2", 3" hose connections
 2", 2 1/2", 3" B.S.P. threaded connections

Weight (without cable)

N: 16.5 kg, W 18 kg

Options and Accessories

Zinc anodes. Surface protection coating
 Bottom suction adapter. Series connection.
 Starter and control units. PumpFloater. Emergency kit. Service kit
 Discharge connection accessories and hose