



# PC1000-1 PC1000LC-1

## HYDRAULIC EXCAVATOR



Model shown may include optional equipment

**FLYWHEEL HORSEPOWER: 542HP @ 1700 RPM.**

**LOADING SHOVEL: OPERATING WEIGHT: 98000kg (216,100 lb). BUCKET CAPACITY: 5.5-7m<sup>3</sup> (7.2-9.2 yd<sup>3</sup>).**

**BACKHOE: OPERATING WEIGHT: 95000 kg (209,400 lb).**

**WITH LC UNDERCARRIAGE: 103300 kg (227,740 lb). BUCKET CAPACITY: 3.1-5.4 m<sup>3</sup> (4.1-7.1 yd<sup>3</sup>).**

- Mode selection system saves fuel by enabling the operator to match pump delivery to job requirements
- EOLSS system reduces fuel consumption and increases efficiency by minimizing hydraulic losses
- Large tinted glass area, adjustable seat and wrist control levers add to the operator's comfort and productivity
- Additional fuel savings from the autodeceleration system which automatically lowers engine speed whenever the work equipment and travel controls are in neutral
- Variable displacement hydraulic pumps modify the rate of oil flow to match the application
- Straight travel valve allows safe, simultaneous operations
- Quiet, fuel-efficient Komatsu SA6D170 turbo diesel
- Electronic display/monitor panel continuously monitors all systems for reduced downtime
- Arm merge circuit reduces cycle time
- SE configuration available for increased production on mass excavation applications

## Operator Comfort for Maximum Productivity



**Human engineered cab** — is both roomy and efficient. The large area of tinted glass allows the operator excellent visibility. Five-way seat with armrests, short stroke wrist-control levers, pull-up front window and travel pedals with levers work together to help your operator maximize production.

**Low-noise operation** — is promoted by advanced EOLSS hydraulics, a closed engine compartment and a rubber mounted engine. All of which contribute to a low noise level inside the cab.

**Wrist control levers** — for easy work equipment operation. The armrest-mounted wrist control levers have a maximum stroke of only 75mm (3") and Komatsu's Proportional Pressure Control System reduces operating effort for precise control of work equipment.

**Swing holding brake** — automatically prevents hydraulic drift of the machine even when it's parked on a slope. The operator is no longer required to physically maintain a braking device during work equipment operation. Also, the swing control is equipped with a closed center spool valve for smooth starts and stops.

**Travel/steering controls** — are foot pedals with detachable lever controls. Either can be used depending on application and operator preference.

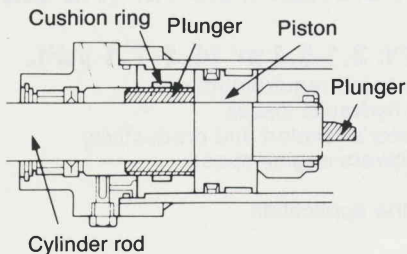

**Cushion mechanism** — in the arm cylinder and head end of boom and bucket cylinders absorbs operating shocks from cylinder extension and retraction, increasing both operating comfort and component life.

## Advanced Hydraulic

### ...Minimized Fuel Consumption

**Mode selection system** — prevents undue fuel and power loss by matching the driving horsepower of the pumps to the specific task at hand. The operator may set the excavator in any one of three modes by simply setting the mode selection switch on the monitoring panel. The Heavy-Duty mode is used when maximum force is required. The Standard-Duty mode is for general digging and loading and the Light-Duty mode enables the operator to maintain quick cycle times and save fuel during light operations (such as slope finishing).

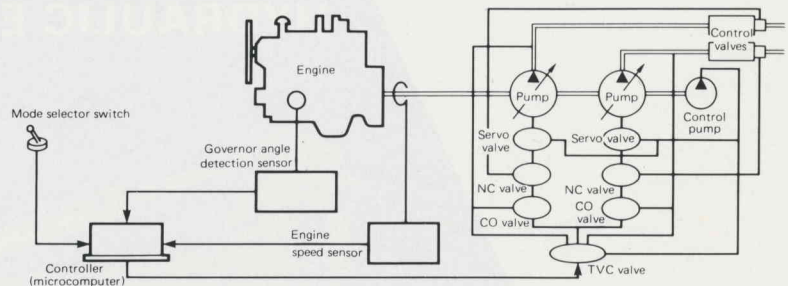

**Electronic Open-center Load Sensing System (EOLSS)** — electronically controls oil flow from the three variable capacity piston pumps so that unnecessary oil flow can be eliminated and fuel consumption significantly reduced. A microcomputer matches oil discharge volume to engine speed (even at high altitudes) so that engine output power can be effectively utilized. This also reduces fuel consumption since the engine is not generating unused power.

**Autodecelerator system** — automatically reduces engine speed when the work equipment and travel controls are in neutral. Why waste fuel waiting on the dump truck? Following a short time delay, so fine control work will not be affected, a solenoid valve automatically slows the engine and saves you fuel.

**Komatsu OLSS System** — minimizes hydraulic loss during operation. This hydraulic sub-system functions to reduce three types of hydraulic loss.

- **Reduction of neutral loss:** When control levers are positioned in neutral, unnecessary oil flow is detected by the Negative Control valve, so the amount of oil discharged from the hydraulic pumps is reduced to a minimum.
- **Reduction of fine control loss:** When precise operation such as finishing, hoisting, centering, or loading into a dump truck is required, a large volume of oil flow is usually wasted. The OLSS detects such unused oil flow in the form of pressure by the jet sensor and minimizes oil generation from the pumps, increasing fuel economy.
- **Reduction of relief loss:** When the work equipment hits a hard obstacle, oil is drained to protect it from damage. In such a case, the OLSS senses the status and the cut-off valve regulates oil output from the pumps in response to the amount of unused oil, resulting in greatly reduced hydraulic loss and noise.

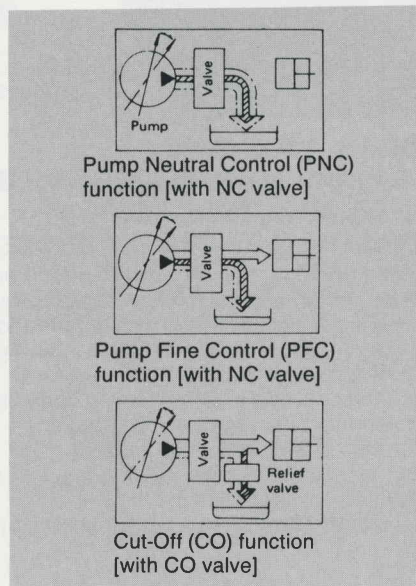

# System Provides...

## ...Smooth Powerful Operation

**Independent swing circuit**— combined with the use of merged arm circuits provide smooth bucket movements and fast cycle times. This three pump system with an independent swing pump allows compound operation of the swing and arm and/or boom circuit without sacrificing speed. This feature is especially valuable in leveling, slope finishing or other application where frequent arm action is required.

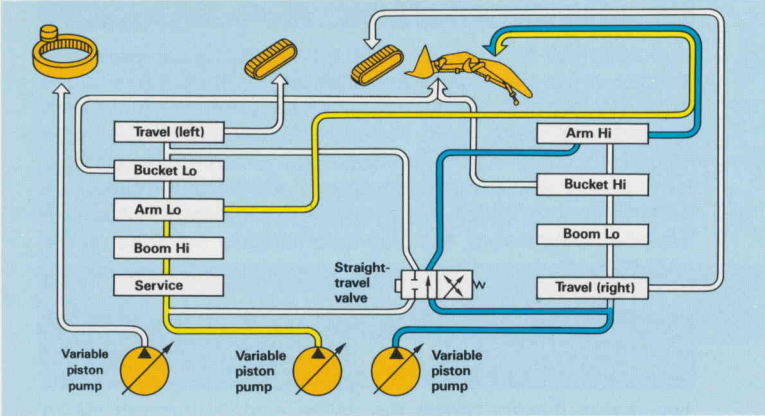

**Super earthmover (SE) configuration** — developed for mass excavation applications, features larger bucket capacity, greater breakout force, shorter cycle times and increased production.

**Circular arc or level digging switch** — eliminates complex lever movements. A three way switch allows the operator to choose between circular arc or level digging. The third switch position activates the bucket angle compensation function during level digging to prevent spillage.

**Straight travel valve** — automatically interlocks the left and right hydraulic circuits allowing the machine to always travel straight, even when simultaneously operating the work equipment.

**Smooth swing action** — is assured with a control-valve-operated swing system. Swing stops and starts are smooth and firm.

**Two speed travel** — allows the machine to achieve extra pulling power during extremely rough ground conditions or uphill travel applications.

**Boom and arm lock valves** — eliminate drift.



**Komatsu SA6D170 diesel engine** — assures low fuel consumption. It delivers an ample 405 kW (542 HP) power, making easy work out of heavy-duty digging and loading. And it adopts a direct-injection fuel system for greatly improved combustion efficiency. In addition, the lightweight design and reduced friction between moving parts further boost fuel economy. The turbocharger and aftercooler allow the SA6D170 to maintain high performance even on high-altitude jobsite.

# At Komatsu the Quality is Standard

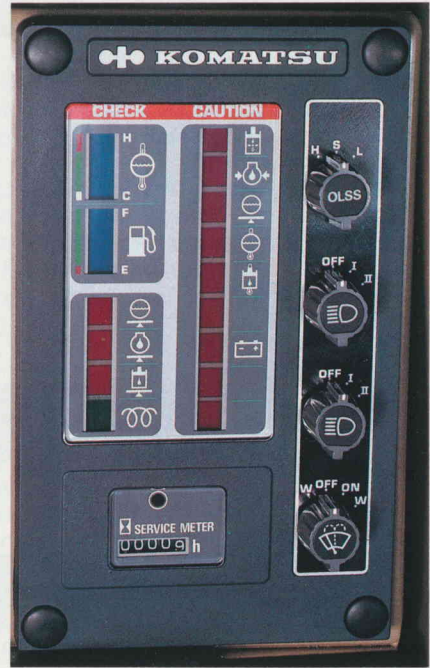

**Electronic monitoring system** — is a display panel that continuously monitors all operating systems. If a malfunction should occur, the operator is immediately warned which system is experiencing trouble, saving valuable time lost searching for the problem. Also, gauges constantly monitor service hours, engine water temperature and fuel level.

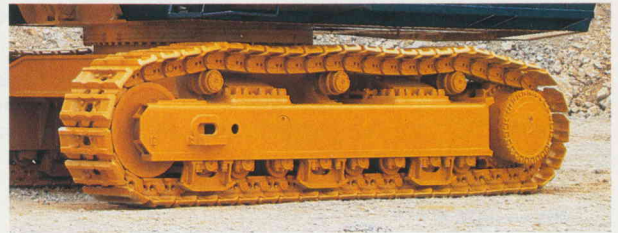

**Largest undercarriage components** — in its class provides extended life. The same undercarriages are used on Komatsu large bulldozers. In addition, the track motor guards which protect the motors from obstacles are standard equipment.

**Variable track gauge** — is provided for shipping convenience. By adjusting the track gauge inward the width of the machine can be decreased by 460 mm (18.1").

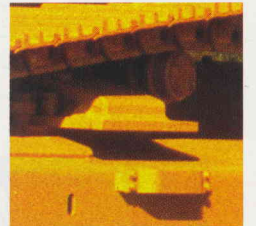

**All components are designed and manufactured by Komatsu for maximum quality and reliability.**

# LOADING SHOVEL SPECIFICATIONS



## ENGINE

Komatsu SA6D170, 4-cycle, water-cooled, overhead-valve, direct-injection, turbocharged diesel engine with aftercooler. Six cylinders of 170 mm (6.69") bore x 170 mm (6.69") stroke and 23.15 ltr. (1,413 in<sup>3</sup>) piston displacement

Flywheel horsepower:

**542 HP (405 kW) at 1700 RPM (SAE J1349)**

Mechanical all-speed control governor. Gear pump-driven force lubrication with full-flow filter. Dry-type air cleaner with an automatic dust evacuator for longer element service intervals and a dust indicator for simplified maintenance. 24-volt electrical starting system.



## HYDRAULIC SYSTEM

Unique three-pump system and independent swing function assure smooth compound movements of the work equipment. Open-center Load Sensing hydraulic system (OLSS) controls all three pumps for efficient engine power use. This system also reduces hydraulic loss during operation, resulting in lowered fuel consumption.

Oil-to-air hydraulic oil cooler maintains optimum heat balance of the hydraulic oil.

### Hydraulic pumps:

Two variable-capacity tandem pumps power the boom, arm, bucket and travel circuits.

Capacity (discharge flow) at rated engine revolutions  
.....2 x 628 ltr. **(166 U.S. Gal)/min**

One variable-capacity piston pump power the swing circuit.

Capacity (discharge flow) at rated engine revolutions  
.....1 x 448 ltr. **(118.0 U.S. Gal)/min**

Tandem gear pump powers the pilot control circuit.

Capacity (discharge flow) at rated engine revolutions  
.....163 ltr. **(43.1 U.S. Gal)/min**

### Hydraulic motors:

Travel .....Four piston motors with brake valve  
(two for each track)

Swing .....Two piston motors with swing holding brake.

### Control valves:

Single-spool type x 1, four-way spool type x 1 and five-way spool type x 1

### Relief valve settings:

Implement circuits .....320 kg/cm<sup>2</sup> **(4551 PSI)**

Travel circuits .....275 kg/cm<sup>2</sup> **(3910 PSI)**

Swing circuits .....290 kg/cm<sup>2</sup> **(4120 PSI)**

Pilot circuits .....30 kg/cm<sup>2</sup> **(427 PSI)**

### Hydraulic cylinders

Cylinder	Number	Bore x Stroke	
Boom	2	225 mm x 1805 mm	<b>(8.9" x 5'11")</b>
Arm	2	180 mm x 1765 mm	<b>(7.1" x 5.9")</b>
Loading Shovel	2	200 mm x 1530 mm	<b>(7.9" x 5')</b>
Bottom Dump	2	140 mm x 435 mm	<b>(5.5" x 1'5")</b>



## STEERING

Steering/traveling controls are activated with either hand levers or foot pedals. Pushing both levers (or pedals) moves machine forward. Pulling them back makes machine go into reverse. Setting one lever (or pedal) in neutral and the other in forward enables machine to make a pivot turn. Pushing one forward while pulling the other backward makes machine counterrotate on the spot.



## DRIVES

Fully hydrostatic drive system. Each track is driven by two hydraulic motors. Power is transferred through spur gears and planetary reduction gears to the track.

Max. drawbar pull .....62000 kg **(136,710 lb)**

Max. travel speed: High .....3.4 km/h **(2.1 MPH)**

Low .....2.4 km/h **(1.5 MPH)**



## BRAKES

Hydraulic lock-type brakes. Each travel motor is equipped with a brake valve. When the travel/steering levers are positioned in neutral, the brakes automatically lock. When the brakes are applied, the brake valve softens shocks and also assures smooth machine starts. The brake valve also serves to regulate speeds when making descents. Oil, multiple-disc type parking brakes, which are hydraulically interconnected with travel/steering levers, are also automatically actuated on the final-drive shaft.



## SWING SYSTEM

Two piston motors power the swing system through swing machineries with spur and planetary reduction gears. The wet disc type swing holding brake built in the swing machinery is automatically applied when the control lever is positioned in neutral. Single-row shear type ball bearings with induction-hardened internal gears are built in the swing circle. Swing speed is 4.5 RPM.

Tail swing radius .....4650 mm **(15'3")**



## UNDERCARRIAGE

Job-proven undercarriage with long track and wide track gauge. Center frame is mounted on the track frames and secured with bolts. Track gauge can be easily reduced by 460 mm (18") for shipping. Sealed tracks. Lubricated rollers and idlers. Hydraulic track tension adjusters with a cushion cylinder. Assembled track-type tractor shoes with double grousers.

Shoe width .....710 mm **(28")**

Grouser height .....20 mm **(0.8")**

Number of shoes (each side) .....51

Number of track rollers (each side) .....8

Number of carrier rollers (each side) .....3

Ground pressure .....1.27 kg/cm<sup>2</sup> **(18.1 PSI)**



## SERVICE REFILL CAPACITIES

Fuel tank .....1140 ltr. **(301 U.S. gal)**

Coolant .....158 ltr. **(42 U.S. gal)**

Engine .....51 ltr. **(14 U.S. gal)**

Final drive (each side) .....45 ltr. **(12 U.S. gal)**

Swing drive (each) .....13 ltr. **(3.4 U.S. gal)**

Hydraulic oil .....650 ltr. **(172 U.S. gal)**

Pump drive .....15 ltr. **(4 U.S. gal)**



## OPERATING WEIGHT (approximate)

Operating weight including 5100 mm (16'9") boom, 3800 mm (12'6") arm, 6.1 m<sup>3</sup> (8.0 yd<sup>3</sup>) SAE heaped bucket, operator, lubricant, coolant, full fuel tank and the standard equipment: 98000 kg **(216,100 lb)**



# DIMENSIONS

Unit: mm (ft.in)

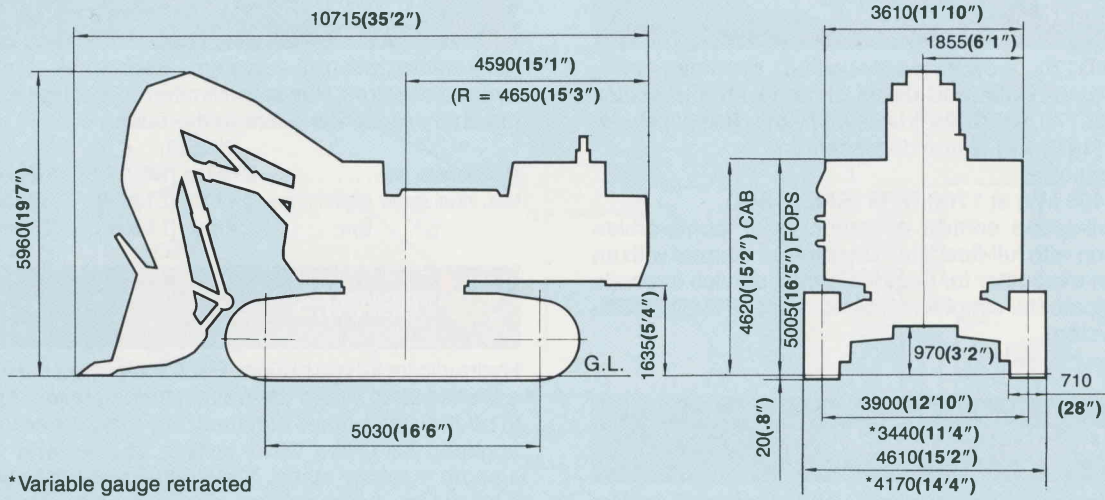

# WORKING RANGE & ATTACHMENTS

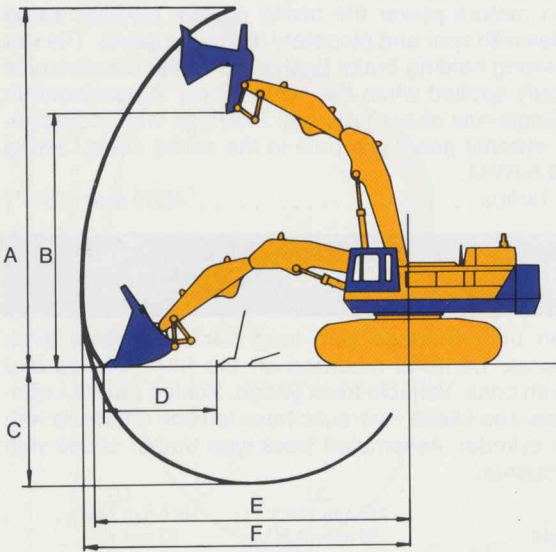

## BUCKET TYPE

Bucket capacity: m <sup>3</sup> (yd <sup>3</sup> ) SAE, PCSA heaped	5.5 (7.2)	6.1 (8.0)	7.0 (9.2)
Struck	4.1 (5.4)	4.7 (6.2)	5.6 (7.3)
Bucket width: mm (in)	2650 (104")	2650 (104")	2650 (104")
Bucket weight: kg (lb) (with teeth)	8400 (18,520)	8200 (18,080)	8550 (18,850)
No. of bucket teeth	6	6	6
Bucket type	Bottom Dump	Bottom Dump	Bottom Dump
Recommended Uses	Rock	General-purpose digging and loading	Light material

	6.1 m <sup>3</sup> (8.0 yd <sup>3</sup> ) bottom dump bucket
A Max. cutting height	12170 (39'11")
B Max. dumping height	8780 mm (28'10")
C Max. digging depth	3910 mm (12'10")
D Level crowding distance	4720 mm (15'6")
E Max. digging reach at ground level	10950 mm (35'11")
F Max. digging reach	11380 mm (37'4")
Digging force (Bucket)	58500 kg (128,968 lb kN)
Digging force (Arm)	56000 kg (123,457 lb kN)

# BACKHOE SPECIFICATIONS



## ENGINE

Komatsu SA6D170, 4-cycle, water-cooled, overhead-valve, direct-injection, turbocharged diesel engine with aftercooler. Six cylinders of 170 mm (6.69") bore x 170 mm (6.69") stroke and 23.15 ltr. (1413 in<sup>3</sup>) piston displacement  
Flywheel horsepower:

**542 HP (405 kW) at 1700 RPM (SAE J1349)**

Mechanical all-speed control governor. Gear pump-driven force lubrication with full-flow filter. Dry-type air cleaner with an automatic dust evacuator for longer element service intervals and a dust indicator for simplified maintenance. 24-volt electrical starting system.



## HYDRAULIC SYSTEM

Unique three-pump system and independent swing function assure smooth compound movements of the work equipment. Open-center Load Sensing hydraulic system (OLSS) controls all three pumps for efficient engine power use. This system also reduces hydraulic loss during operation, resulting in lowered fuel consumption.

Oil-to-air hydraulic oil cooler maintains optimum heat balance of the hydraulic oil.

### Hydraulic pumps:

Two variable-capacity tandem pumps power the boom, arm, bucket and travel circuits.

Capacity (discharge flow) at rated engine revolutions  
..... 2 x 628 ltr. (166 U.S. Gal)/min  
One variable-capacity piston pump power the swing circuit.

Capacity (discharge flow) at rated engine revolutions  
..... 1 x 448 ltr. (118.0 U.S. Gal)/min  
Tandem gear pump powers the pilot control circuit.

Capacity (discharge flow) at rated engine revolutions  
..... 163 ltr. (43.1 U.S. Gal)/min

### Hydraulic motors:

Travel ..... Four piston motors with brake valve  
(two for each track)

Swing ..... Two piston motors with swing holding brake.

### Control valves:

Single-spool type x 1, four-way spool type x 1 and five-way spool type x 1

### Relief valve settings:

Implement circuits ..... 320 kg/cm<sup>2</sup> (4551 PSI)  
Travel circuits ..... 275 kg/cm<sup>2</sup> (3910 PSI)  
Swing circuits ..... 290 kg/cm<sup>2</sup> (4120 PSI)  
Pilot circuits ..... 30 kg/cm<sup>2</sup> ( 427 PSI)

### Hydraulic cylinders

Cylinder	Number	Bore x Stroke
Boom	2	225 mm x 2200 mm x (8.9" x 7'3")
Arm	1	250 mm x 2015 mm x (9.8" x 6'7")
Bucket	1	225 mm x 1630 mm x (8.9" x 5'4")



## STEERING

Steering/traveling controls are activated with either hand levers or foot pedals. Pushing both levers (or pedals) moves machine forward. Pulling them back makes machine go into reverse. Setting one lever (or pedal) in neutral and the other in forward enables machine to make a pivot turn. Pushing one forward while pulling the other backward makes machine counterrotate on the spot.



## DRIVES

Fully hydrostatic drive system. Each track is driven by two hydraulic motors. Power is transferred through spur gears and planetary reduction gears to the track.

	Std.	LC
Max. drawbar pull.....	62000 kg (136,710 lb)	69000 kg (152,145 lb)
Max. travel speed: High.....	3.4 km/h (2.1 MPH)	3.2 km/h (2.0 MPH)
Low.....	2.4 km/h (1.5 MPH)	2.1 km/h (1.3 MPH)



## BRAKES

Hydraulic lock-type brakes. Each travel motor is equipped with a brake valve. When the travel/steering levers are positioned in neutral, the brakes automatically lock. When the brakes are applied, the brake valve softens shocks and also assures smooth machine starts. The brake valve also serves to regulate speeds when making descents. Oil, multiple-disc type parking brakes, which are hydraulically interconnected with travel/steering levers, are also automatically actuated on the final-drive shaft.



## SWING SYSTEM

Two piston motors power the swing system through swing machineries with spur and planetary reduction gears. The wet disc type swing holding brake built in the swing machinery is automatically applied when the control lever is positioned in neutral. Single-row shear type ball bearings with induction-hardened internal gears are built in the swing circle. Swing speed is 4.5 RPM.

Tail swing radius ..... 4650 mm (15'3")



## UNDERCARRIAGE

Job-proven undercarriage with long track and wide track gauge. Center frame is mounted on the track frames and secured with bolts. Variable track gauge. Sealed tracks. Lubricated rollers and idlers. Hydraulic track tension adjusters with a cushion cylinder. Assembled track-type tractor shoes with double grousers.

	Std.	LC
Shoe width.....	710 mm (28")	1010 mm (40")
Grouser height.....	20 mm (0.8")	50 mm (2")
No. of shoes (ea. side).....	51	58
No. of track rollers (ea. side).....	8	10
No. of carrier rollers (ea. side).....	3	3
Ground pressure.....	1.27 kg/cm <sup>2</sup> (18.1 psi)	0.8 kg/cm <sup>2</sup> (11.4 psi)



## SERVICE REFILL CAPACITIES

Fuel tank ..... 1140 ltr. (301 U.S. gal)  
Coolant..... 158 ltr. ( 42 U.S. gal)  
Engine ..... 51 ltr. ( 14 U.S. gal)  
Final drive (each side) ..... 45 ltr. ( 12 U.S. gal)  
Swing drive (each)..... 13 ltr. ( 3.4 U.S. gal)  
Hydraulic oil..... 650 ltr. (172 U.S. gal)  
Pump drive..... 15 ltr. ( 4 U.S. gal)



## OPERATING WEIGHT (approximate)

Operating weight including 9250 mm (30'4") boom, 3400 mm (11'3") arm, 4.3 m<sup>3</sup> (5.6 yd<sup>3</sup>) SAE heaped bucket, operator, lubricant, coolant, full fuel tank and the standard equipment: 95000 kg (209,400 lb). With LC undercarriage: 103300 kg (227,740 lb). SE configuration on standard undercarriage 97000 kg (213,850 lb).



**DIMENSIONS** With 9.25m (30'4") Boom, 3.4m (11'3") arm and 4.3m³ (5.6 yd³) Bucket

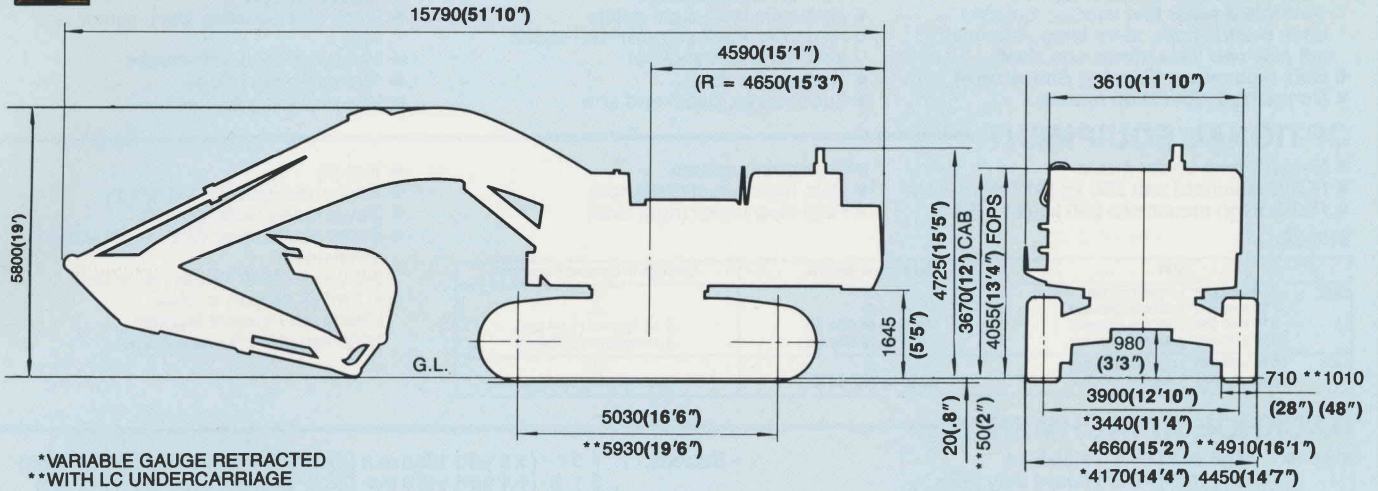

**WORKING RANGE & ATTACHMENT**

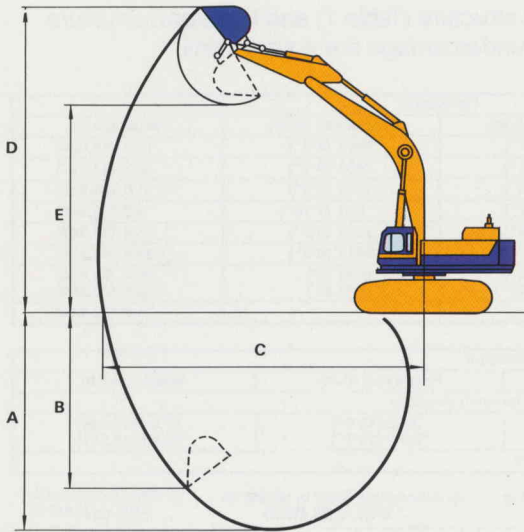

**BUCKET TYPE**

Bucket capacity: m³ (yd³)					
SAE, PCSA heaped	3.1 (4.1)	3.7 (4.8)	4.3 (5.6)	5.4 (7.1)	5.7 (7.45)
Struck	2.3 (3.0)	2.7 (3.5)	3.2 (4.2)	5.3 (6.0)	—
Bucket width: mm (in)					
without side cutters	1480 (58.3")	1690 (66.5")	1890 (74")	2100 (82.7")	1950 (76.8")
with side cutters	1650 (65")	1860 (73.2")	2060 (81.1")	2270 (89.4")	2120 (83.5")
Bucket weight: kg (lb)					
(with teeth)	3100 (6,830)	3600 (7,940)	3800 (8,380)	4350 (9,590)	5200 (11,460)
without side cutters					
with side cutters	3300 (7,280)	3800 (8,380)	4000 (8,820)	4550 (10,030)	5400 (11,900)
No. of bucket teeth	4	4	5	5	5
Bucket type	Narrow bucket	Narrow Bucket	Standard Bucket	Light Duty	SE

**Recommendation for bucket and boom/arm combination**

Bucket (SAE heaped)	Boom	7.9m (25'11") Short Boom	7.9m (25'11") Short Boom	9.25m (30'4") Standard Boom		
	Arm	3.42m (11'3") SE Arm	3.42m (11'3") Standard Arm	3.42m (11'3") Standard Arm	4.5m (14'9") Semi-long Arm	5.6m (18'4") Long Arm
SE bucket 5.7m³ (7.45 yd³)		△	—	—	—	—
Light-duty bucket, 5.4 m³ (7.1 yd³)		—	□	△	—	—
Standard bucket, 4.3 m³ (5.6 yd³)		—	○	□	△	—
Narrow bucket, 3.7 m³ (4.8 yd³)		—	—	○	□	△
Narrow bucket, 3.1 m³ (4.1 yd³)		—	—	—	○	□
A. Max. digging depth	mm (ft. in)	7970 (26'2")	7890 (25'11")	9290 (30'6")	10390 (34'1")	11490 (37'8")
B. Max. vertical wall depth		6000 (19'8")	6990 (22'11")	7090 (23'4")	9350 (30'8")	10540 (34'7")
C. Max. digging reach		13940 (45'9")	13900 (45'7")	15300 (50'2")	16260 (53'4")	17290 (56'9")
D. Max. digging height		13030 (42'9")	13070 (42'11")	13410 (44")	13890 (45'7")	14310 (46'11")
E. Max. dumping height		8270 (27'2")	8590 (28'2")	9010 (29'7")	9480 (31'1")	9880 (32'11")
Arm crowd force	ton	34000 (74,956)	34000 (74,956)	34000 (74,956)	28000 (61,728)	24300 (53,571)
Bucket digging force	(lb)	40000 (88,180)	37000 (81,570)	37000 (81,570)	37000 (81,570)	37000 (81,570)

- △: Light-duty work up to 1.8t/m³ (3000 lb/yd³)
- : General work (Specific gravity, up to 2.0t/m³ (3,400 lb/yd³))
- : Heavy-duty work (Specific gravity, above 2.0t/m³ (3,400 lb/yd³))

## STANDARD EQUIPMENT

- Air conditioner with heater defroster
- Air cleaner, dry type with auto evacuator
- Alternator (50A)
- Auto decelerator
- Cab includes: tinted safety glass, windshield wiper and washer, lockable door, electric horn, room lamp, floor mat left side rear view mirror, sun visor.
- Cab, high mount (Loading Shovel only).
- Centralized lubrication system

- Counterweight 14000 kg (32,000 lb)
- Electronic open center load sensing hydraulic system
- Front lights (2)
- Fuel level sight gauge
- Hydraulic level sight gauge
- Hydraulic track adjuster with shock absorbing accumulator
- Hydrostatic drive
- Lock valves, boom and arm

- Monitoring system
- Proportional pressure control system
- Seat, suspension and reclining with seat belt
- Tracks, sealed
- Track roller guards, front, center, and rear
- Vandalism protection locks
- Variable track gauge
- Wet disc track brakes

## OPTIONAL EQUIPMENT

- Center frame under guard
- FOPS, standard cab 280 kg (617 lb)
- FOPS, high mount cab 280 kg (617 lb)

- Free swing system
- Cab, high mount (Backhoe)
- Rear view mirror (right side)

- Tool kit
- Track roller guards, full length
- Travel motor underguards
- Super earthmover (SE) configuration consists of:
  - 3420 mm (11'3") heavy duty arm
  - 5.7 m<sup>3</sup> (7.45 yd<sup>3</sup>) bucket
  - Heavy duty bucket linkage
  - 7900mm (25'1") short boom

## SHOES

Type	Additional Weight	Change in Ground Pressure
Std:		
710 mm (28") triple grouser	-0-	-0-
710 mm (28") double grouser	-0-	-0-
910 mm (36") double grouser	2250 kg (4,960 lb)	-0.14 kg/cm <sup>2</sup> (1.99 psi)
1010 mm (40") double grouser	3100 kg (6,839 lb)	-0.19 kg/cm <sup>2</sup> (2.70 psi)
LC:		
1010 mm (40") double grouser	-0-	-0-
1210 mm (48") double grouser	2338 kg (5,155 lb)	-0.12 kg/cm <sup>2</sup> (1.71 psi)

## BACKHOE ATTACHMENTS

- Arms: 3420 mm (11'3") standard  
3420 mm (11'3") heavy duty (SE)  
4500 mm (14'9") semi-long  
5600 mm (18'4") long
- Booms: 9250 mm (30'4") standard  
7900 mm (25'1") short
- Buckets: 4.3 m<sup>3</sup> (5.6 yd<sup>3</sup>) 1880 mm (72.4") standard with hook & 5 teeth  
3.1 m<sup>3</sup> (4.1 yd<sup>3</sup>) 1480 mm (58.3") narrow with hook & 4 teeth  
3.7 m<sup>3</sup> (4.8 yd<sup>3</sup>) 1690 mm (66.5") narrow with hook & 4 teeth  
5.4 m<sup>3</sup> (7.1 yd<sup>3</sup>) 2330 mm (91.7") light duty with hook & 5 teeth
- Side cutters: 5.7 m<sup>3</sup> (7.4 yd<sup>3</sup>) 2120 mm (83.5") (SE) with hook & 5 teeth

## LOADING SHOVEL ATTACHMENT

- Arm: 3800 mm (12'6")
- Boom: 5100 mm (16'9")
- Buckets: 6.1 m<sup>3</sup> (8.0 yd<sup>3</sup>) 2650 mm (104") bottom dump with 6 teeth  
5.5 m<sup>3</sup> (7.2 yd<sup>3</sup>) 2650 mm (104") rock bottom dump with 6 teeth  
7.0 m<sup>3</sup> (9.2 yd<sup>3</sup>) 2650 mm (104") light duty bottom dump with 6 teeth

## TRANSPORTATION GUIDE

The structural divisions of the PC1000-1 fall into two categories: the four-part structure (Table 1) and three-part structure (Table 2). In the case of the three-part structure, the upper structure and the undercarriage are a single unit.

Table 1

1	Work equipment (Loading shovel)	Dimension			
		Length mm (ft.in)	Width mm (ft.in)	Height mm (ft.in)	Weight ton (lb)
1	Boom, Arm	8720 (28'7")	2000 (6'7")	2600 (8'6")	14.8 (32,628)
	Bucket	2570 (8'5")	2800 (9'2")	2660 (8'9")	10.3 (22,707)
1	Work equipment (Backhoe)				
	Boom	9600 (31'6")	2850 (9'4")	1410 (4'8")	11.0 (24,250)
	Arm	4900 (16'1")	1550 (5'1")	550 (1'10")	4.8 (10,582)
	Bucket	2520 (8'3")	2050 (6'9")	1890 (6'2")	6.4 (14,109)
2	Upper structure	6670 (21'11")	3480 (11'5")	2945 (9'8")	30.0 (66,135)
3	Undercarriage	6355 (20'10")	1655 (5'5")	1530 (5')	28.4 (62,610)
		*7215 (23'8")	*1805 (5'11")	*1523 (5')	*35.6 (78,450)
4	Other (counterweight)				14.9 (32,848)

Table 2

1	Work equipment	Dimension			Weight ton (lb)
		Length mm (ft.in)	Width mm (ft.in)	Height mm (ft.in)	
1	Work equipment	The same as four-part structure			
6	Base machine	7525 (24'8") *7955 (26'1")	4150 (13'7") *4450 (14'7")	3800 (12'6") *3840 (12'7")	57.9 (127,646) *65.6 (144,585)
4	Others (counterweight)	The same as four-part structure			

### Transport structure ■ Four-part structure

- ① Work equip. ass'y (L/S) 25100 kg (55,335 lb)    ① Work equip. ass'y (Backhoe) 22200 kg (48,942 lb)

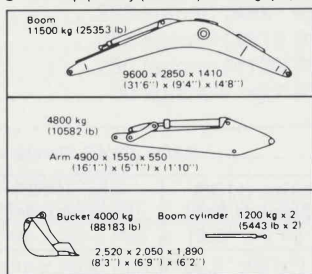
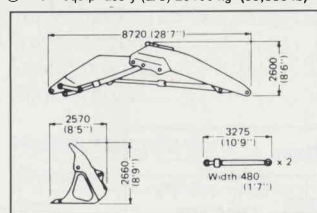

- ② Upper structure 30000 kg (66,140 lb)    ③ Undercarriage 28400 kg (62,610 lb) \*35580 kg (78,450 lb)    ④ Others (Counterweight) 14900 kg (32,848 lb)

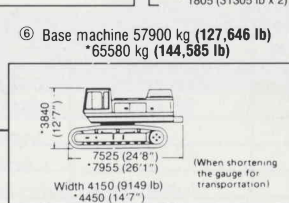
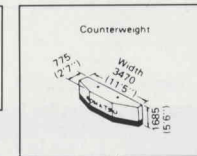
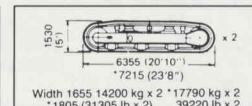
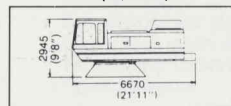

### ■ Three-part structure

It is possible in some U.S. states to transport in a three-part structure.

- ① Work equipment ass'y

\*LC undercarriage  
AESS287-03

Materials and specifications are subject to change without notice

**KOMATSU**

ÉQUIPEMENT FÉDÉRAL QUÉBEC LIMITÉE  
 CASE POSTALE 1447, SUCC. ST-LAURENT  
 ST-LAURENT, QC H4L 4Z1  
 VENTES - PIÈCES - SERVICE  
 (514) 341-4590 ou sans frais 1-800-361-1412