

# Crawler Tractors

**PR 736**  
Litronic®

**PR 746**  
Litronic®

**PR 756**  
Litronic®

Operating Weight:

20,300 – 24,600 kg / 44,750 – 54,230 lb

28,300 – 30,800 kg / 62,370 – 67,900 lb

38,300 – 41,150 kg / 84,430 – 90,720 lb

Engine Output:

150 kW / 204 HP

185 kW / 252 HP

250 kW / 340 HP

Stage IV / Tier 4f



# LIEBHERR

## PR 736 Litronic

---

### Engine:

150 kW/204 HP

Emission Stage IV/Tier 4f

### Operating weight:

20,300 – 24,600 kg

44,750 – 54,230 lb

### Blade capacity:

4.10 – 5.56 m<sup>3</sup>

5.36 – 7.27 yd<sup>3</sup>

### Hydrostatic travel drive

with electronic control unit

## PR 746 Litronic

---

### Engine:

185 kW/252 HP

Emission Stage IV/Tier 4f

### Operating weight:

28,300 – 30,800 kg

62,370 – 67,900 lb

### Blade capacity:

6.00 – 7.20 m<sup>3</sup>

7.85 – 9.42 yd<sup>3</sup>

### Hydrostatic travel drive

with electronic control unit

## PR 756 Litronic

---

### Engine:

250 kW/340 HP

Emission Stage IV/Tier 4f

### Operating weight:

38,300 – 41,150 kg

84,430 – 90,720 lb

### Blade capacity:

8.92 – 11.70 m<sup>3</sup>

11.67 – 15.3 yd<sup>3</sup>

### Hydrostatic travel drive

with electronic control unit

## Performance

Outstanding pushing and  
ripping performance



## Efficiency

Cost efficiency comes standard

## Reliability

Robust design in every regard

## Comfort

Ample space, ergonomics and comfort – All in one

## Maintainability

Simple maintenance and an extensive service network



# Performance



## Outstanding pushing and ripping performance

Power and innovative technology are the hallmarks of Liebherr crawler tractors. Whether for heavy ripping work, moving material or fine-grading, Generation 6 crawler dozers are powerful machines for every application.

## High productivity

### Powerful engines ...

Liebherr diesel engines are designed for the harsh conditions of construction sites and provide the right amount of power in every situation. Depending on the job requirements different operating modes are available for maximum power or fuel-saving operation.

### ... and an intelligent drive system

The hydrostatic travel drive operates smoothly and automatically adjusts the working speed to the load conditions. The engine's power is always transmitted to both tracks without interruption. This permits exact and powerful steering; track slip is minimised and operators can concentrate completely on their work.

### Safe on every terrain

The drive components have been placed to provide a very low centre of gravity while still ensuring maximum ground clearance. Together with solid belly pans this permits safe, reliable operation when performing challenging work on slopes and embankments. For even better traction, the PR 756 undercarriage can be configured with bogie suspension.

### Liebherr-Hydrostatic drive

- Automatic speed and torque adjustment optimises transmission of engine power to the tracks as the load changes.
- The high efficiency of the hydrostatic drive is available over almost the entire speed range. The drive's capabilities are especially beneficial when performing heavy pushing and ripping work.

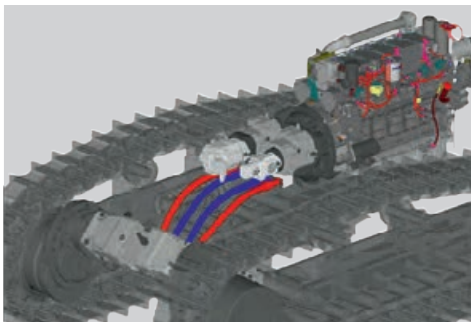

## Precise control

### Excellent maneuverability

When working in tight areas, the hydrostatic travel drive offers an additional benefit. All steering motions – including turning on the spot – are fast and effortless. In ripping work, the ripper can be positioned precisely between hard layers of rock and break out the material with ease.

### Outstanding grading characteristics

Crawler tractors in the mid-sized class must provide maximum versatility. Generation 6 crawler dozers from Liebherr offer an exceptionally smooth ride, precision blade control and a perfect view of the blade. This ensures maximum productivity both when pushing heavy material and when fine-grading.

### Automatic machine control

2-D or 3-D machine control is becoming increasingly indispensable to enhancing the productivity of the operator and machine. Thanks to their stepless drive concept, Liebherr crawler tractors are ideal for this type of control. Factory-installed preparation kits are offered for all common systems, giving customers maximum flexibility when selecting the control system that best meets their needs.

### Intelligent engine control

- The electronically modelled power and torque curves ensure outstanding pushing power and a dynamic response to increasing loads.
- On-demand power boost assures adequate power reserves, even under the most difficult working conditions.



### Precise finegrading

- Long tracks and an extremely rigid oscillating bar keep the machine well balanced.
- The precise working hydraulics and perfect matching of equipment and base machine provides optimal blade control at all times.



# Efficiency



## Cost efficiency comes standard

Liebherr crawler tractors are designed from the ground up with economy in mind. A highly efficient drive concept, components with long service lives and low maintenance requirements reduce operating costs – and increase your profits.

## Unrivalled economy

### The latest engine and exhaust technology

The newest generation of Liebherr diesel engines complies with Emission Stage IV/Tier 4 final. SCR technology: the exhaust gas undergoes selective catalytic reduction through injection of urea (DEF, AdBlue®). A diesel particulate filter is not required. As a result, the engine operates in a temperature range of maximum efficiency. The constant, low engine speed, in combination with common rail injection, ensures optimised cylinder charging and, in turn, even more efficient fuel combustion.

### Highly efficient driveline

The high efficiency of the hydrostatic drive extends over almost the entire speed range. The engine's power is transmitted with minimum loss and fuel consumption is further reduced.

### Lower CO<sub>2</sub> emissions

With exhaust emission values that comply with the most stringent legislation and even greater fuel economy than that of previous models, Liebherr Generation 6 crawler dozers sets new standards for environmental friendliness. The "ecological footprint" is smaller than ever.

## Optimised for every job

### A variety of track options

Thanks to various track sizes and track shoe options offered, Liebherr crawler tractors can be ideally configured for specific operating conditions – no matter if in rocky terrain, on steep slopes or soft ground.

### Undercarriage with rotary bushings

As the perfect feature when working on very abrasive ground, Liebherr offers tracks with free-turning bushings (FTB). The large, rotating bushings minimise track and sprocket wear; in addition, chain links and rollers have even more wear material. This extends the service life of the entire undercarriage considerably in these specific applications.

### Equipment for special applications

Applications such as handling of coal, wood chips or waste place enormous demands on crawler tractors. Specially developed equipment kits ensure maximum productivity and a long service life, even under these harsh operating conditions.

### Eco-Mode

- The selectable Eco-Mode reduces the engine speed at the push of a button while maintaining the necessary power and lowering fuel consumption. Ideal for light- and medium-duty applications.
- If the machine idles for an extended period of time, the engine can shut down automatically and avoid wasting fuel needlessly.

### PR 736 with 6-way blade

- Material deposition, filling up trenches, creating embankments or finish grading: the 6-way blade gives the PR 736 maximum versatility.
- The optional blade with hinged corners limits the transport width to 3 m. Transporting the machine is fast and inexpensive.

### Always informed with LiDAT

- The Liebherr LiDAT data transmission and positioning system contributes to effective fleet management.
- Utilising the latest communication technology, LiDAT provides comprehensive operational data, allowing economical machine management, optimised resources, and remote monitoring.



# Reliability



## Robust design in every regard

Today's construction sites require machines with maximum versatility and ruggedness. Crawler tractors from Liebherr meet these requirements in an ideal manner: Thanks to components designed specifically for construction machinery, proven technology and innovative customer-specific solutions, you can expect maximum availability.



## Liebherr driveline

### Long-lasting engines

Diesel engines from Liebherr have powered construction machinery around the world for decades. Developed for the harshest operating conditions, their rugged construction and low nominal operating speed guarantee maximum reliability and a long service life.

### Wear-free drive concept

The proven Liebherr hydrostatic travel drive does not need components such as a torque converter, manual gearbox, differential steering or steering clutches. The high-quality hydraulic pumps and motors operate reliably and practically without wear.

### Long-lasting final drives

The large final drives used in the Generation 6 crawler dozers are extremely robust and designed for the heaviest loads. Double mechanical seals with monitoring for leaks ensure reliable operation.

## Rugged design

### Main frame with a proven box-section design

The main frame is constructed using a proven box-section design, which provides maximum torsional stiffness and optimal absorption of forces. Cast steel is used for components subjects to high stress.

### Optimised equipment

L-shaped, welded push frames offer maximum strength and precise blade control. High-strength steel blades and optional, additional wear plates ensure a long service life. All ripper types are designed for heavy-duty ripping work, and areas exposed to wear are given special protection.

### An intelligent cooling system

Hydraulically driven fans are activated as needed to regulate the operating temperature independently of the engine's speed. This guarantees short warm-up times and reliable cooling – even in extremely dusty surroundings. For especially critical operating conditions, a fan that reverses automatically can be provided.

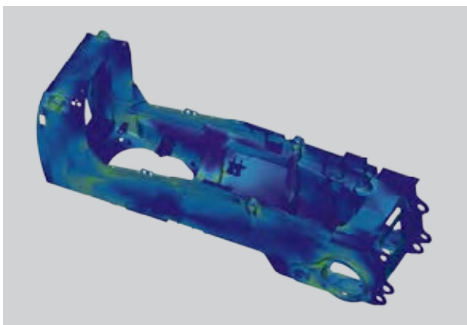

### From the screen to the construction site

- Optimised layout: at the development stage components are designed with state-of-the-art software tools.
- Extensive test bench runs are the next important step in the development process.
- Long-term field tests under rigorous conditions ensure maximum machine availability.

### Key technologies from Liebherr

- Liebherr has decades of experience in developing, designing and manufacturing components and, as a result, offers maximum reliability.
- Important key components such as diesel engines, splitterboxes, hydraulic pumps, hydraulic cylinders, final drives and electronics are manufactured in our own facilities, optimised for combined operation and representing the highest quality.

### Optimised track components

- Noticeably larger sprockets on the PR 736 and PR 746 ensure maximum wear resistance.
- The track tensioner is fully encapsulated and, as a result, ideally protected against material ingress.
- As a further measure, the temperature of the final drives is monitored continuously, which increases the operating reliability of the machine even more.

# Comfort



## Comfort, space and ergonomics: All in one

The completely redesigned working environment offers exceptional operator comfort. With its generous space, ergonomic layout and low sound levels, the Liebherr comfort cab provides the perfect conditions for fatigue-free and concentrated work.

## Deluxe cab

### Ergonomic and purposely designed

The well-thought-out design of the operator's cab provides the best prerequisites for relaxed and productive work. All instruments and operating controls are carefully organised for easy reach. An unobstructed view of the work equipment and perfect all-round visibility allows the operator to concentrate fully on the task at hand.

### Convenience in daily use

Carefully considered details such as a cooled storage compartment, additional footrests, adjustable joysticks and a powerful air conditioning system improve the operator's comfort and boost daily productivity.

### Quiet and dust-free

Thanks to effective sound insulation and modern, low-noise diesel engines, the PR 736, PR 746 and PR 756 feature extremely low noise levels that lie well below the legal limits. The pressurised cab keeps the operator's environment free of dust from the surroundings.

## Simple and intuitive operation

### Single-lever control

All driving functions can be controlled smoothly and precisely with only one operating lever – including the “turning on the spot” function. The travel joystick is optionally available in either a proportional or a detented version – this allows control to be matched optimally to the needs of the operator.

### Safety-Plus comfort seat

The standard air-sprung seat adjusts perfectly to the operator and deactivates the machine automatically on exiting the cab.

### The hydrostatic drive as service brake

The crawler tractor operates with continuous power on both tracks even when driving on slopes. Thanks to the self-locking nature of the hydrostatic drive system, the operator can bring the machine to a stop at any time simply by returning the joystick to the “neutral” position – or by depressing the inching pedal. An automatically activated parking brake provides additional safety.



### Individual set-up

- The intuitive touch-controlled screen conveniently displays all important operating data.
- At the push of a button, the operator can adjust a wide variety of machine settings – for example, the response of the travel drive – precisely to his needs.

### Intuitive control

- The new, ergonomically shaped joysticks are adjustable forward and back.
- 3 speeds can be programmed individually.
- In addition, an inching pedal is available. It can be operated with or without lowering the engine speed – perfect customisation for the operator.

### Unrivalled visibility

- A plus for safety: larger panoramic windows, downward-sloping edges all-round and the integrated ROPS/FOPS protection give the operator unmatched all-round visibility.
- Greater productivity: thanks to a higher seat position, wider doors and optimised engine covers, the operator always has an excellent view of the work equipment.

# Maintainability

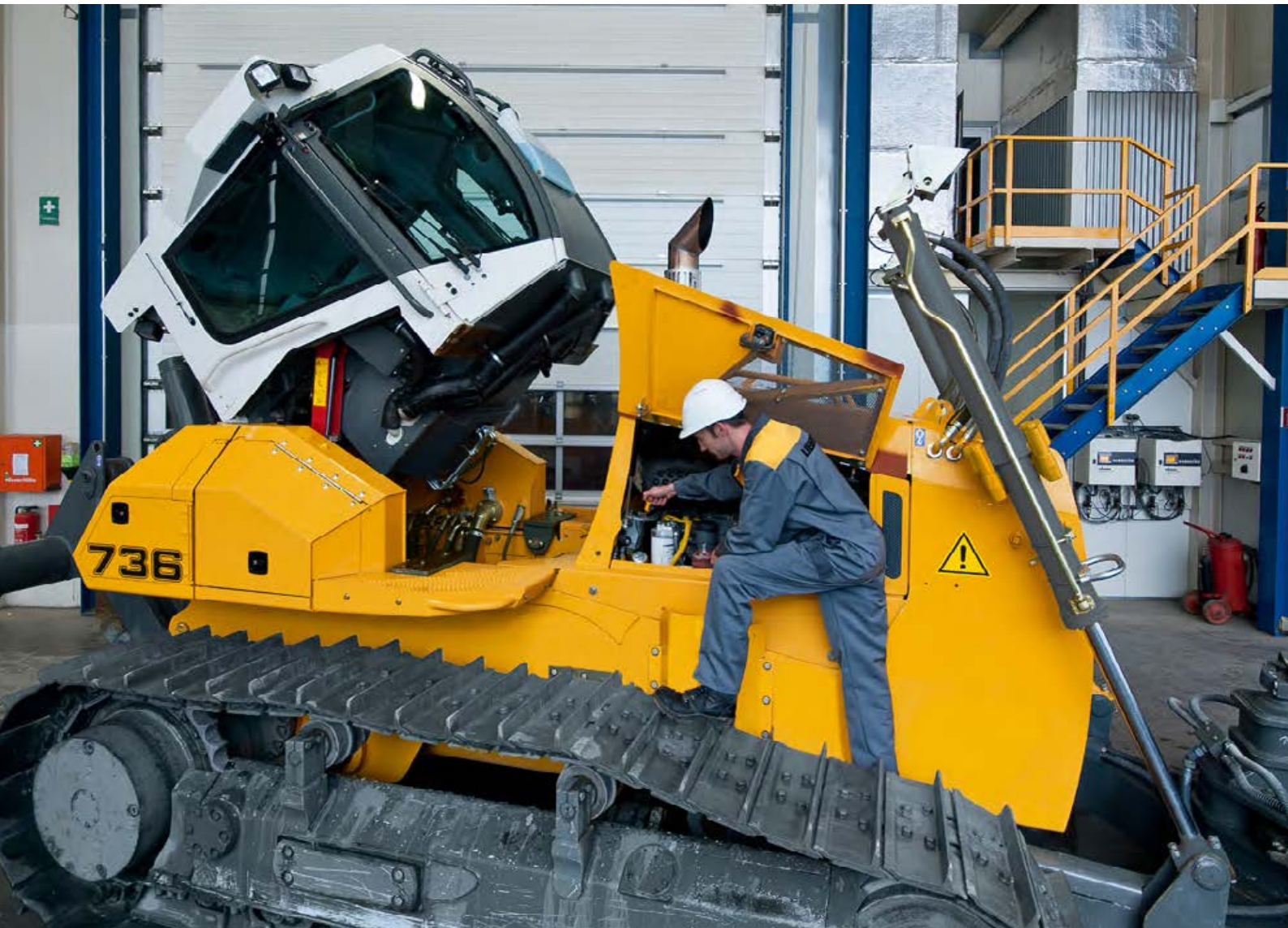

## Simple maintenance and an extensive service network

Thanks to their minimal maintenance requirements, Liebherr crawler tractors make a reliable contribution to your economic success. A dense service network means short distances, efficient structures and fast response times for the user.

## Cost-effective maintenance

### Simple daily checks

All items that the operator checks during daily routine inspections are readily accessible on one side of the engine. The hydraulically tilted cab provides easy access to components as well. Service work can be performed quickly and efficiently.

### Long maintenance intervals

The maintenance intervals are optimally matched to the individual components. Maintenance-free mountings are often used in exposed areas. Hydraulic oil change intervals of up to 8,000 operating hours reduce costs and minimise downtime.

## Optimal planning

### Planned costs

Liebherr crawler dozers come with extensive standard warranties for the entire machine and the drive train. Customised inspection and service programs allow optimal planning of all maintenance activities.

### Remanufacturing

The Liebherr remanufacturing program offers cost-effective reconditioning of components to the highest quality standards. Various reconditioning levels are available: Replacement components, general overhaul or repair. The customer receives components with original part quality at a reduced cost.

## The focus is on the customer

### Competent advice and service

Competent advice is a given at Liebherr. Experienced specialists provide decision-guidance for your specific requirements: application-oriented sales support, service agreements, original parts management, as well as remote data transmission for machine planning and fleet management.

### Continuous dialogue with users

We utilise the expert knowledge and practical experience of our customers to consistently optimise our machines and services – real solutions for real situations.

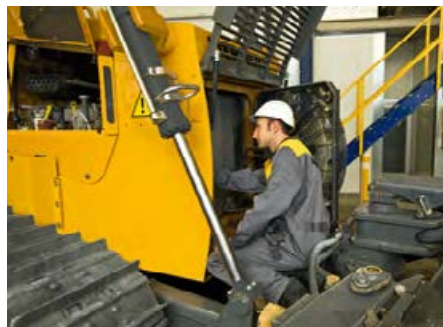

### Easy access

- All service points are centrally located and easily accessible. Thanks to wide-opening access doors, the daily inspection of the machine is simple and time-saving.
- Lubrication points for the oscillating bar bearings are easily reached in the engine compartment.
- The standard lighting of the engine area simplifies maintenance and inspection.

### Tilt-out cooling fan

- In especially dusty applications, the swing-out fan in Generation 6 crawler tractors contributes significantly to easy cleaning of the cooling system. The radiator grille requires no tools to open.
- The additional hydraulic oil cooler fan at the rear of models PR 746 and PR 756 is also hinged.

### Rapid spare parts service

- 24-hour delivery: Spare parts service is available for our dealers around the clock.
- Electronic spare parts catalogue: Fast and reliable selection and ordering via the Liebherr online portal.
- With online tracking, the current processing status of your order can be viewed at any time.

# Technical Data PR 736



## Engine

<b>Liebherr Diesel engine</b>	D 934 A7 Emission regulations according to 97/68/EC, 2004/26/EC Stage IV, EPA/CARB Tier 4f
<b>Rated power (net)</b>	
ISO 9249	150 kW/204 HP
SAE J1349	150 kW/201 HP
<b>Maximum power (net)</b>	
ISO 9249	175 kW/238 HP
SAE J1349	175 kW/235 HP
<b>Rated speed</b>	1,800 rpm
<b>Displacement</b>	7.0 l/427 in <sup>3</sup>
<b>Design</b>	4 cylinder in-line engine, water-cooled, turbocharged, air-to-air intercooler
<b>Injection system</b>	Direct fuel injection, Common Rail, electronic control
<b>Lubrication</b>	Pressurised lube system, engine lubrication guaranteed for inclinations up to 45°, on all sides
<b>Operating voltage</b>	24 V
<b>Alternator</b>	140 A
<b>Starter</b>	7.8 kW/11 HP
<b>Batteries</b>	2 x 180 Ah/12 V
<b>Air cleaner</b>	Dry-type air cleaner with pre-cleaner, main and safety elements, control light in the operator's cab
<b>Cooling system</b>	Combi radiator, comprising radiators for water, hydraulic fluid, charge air. Hydrostatic fan drive



## Hydraulics

<b>Hydraulic system</b>	Load sensing (demand-controlled)
<b>Pump type</b>	Swash plate piston pump
<b>Pump flow max.</b>	207 l/min./45.5 Imp.gpm
<b>Pressure limitation</b>	260 bar/3,770 psi (6-way blade) 200 bar/2,900 psi (Straight blade)
<b>Control valve</b>	2 segments, expandable to 4
<b>Filter system</b>	Return filter with magnetic rod in the hydraulic tank
<b>Control</b>	Single joystick for all blade functions



## Travel Drive, Control

<b>Transmission system</b>	Infinitely variable hydrostatic travel drive, independent drive for each track
<b>Travel speed*</b>	Continuously variable
Speed range 1 (reverse):	0 – 4.0 km/h/2.5 mph (4.5 km/h/2.8 mph)
Speed range 2 (reverse):	0 – 6.0 km/h/3.7 mph (8.0 km/h/4.9 mph)
Speed range 3 (reverse):	0 – 11.0 km/h/6.8 mph (11.0 km/h/6.8 mph)
	* Travel speed ranges can be set on the travel joystick (memory function)
<b>Electronic control</b>	The electronic system automatically adjusts travel speed and drawbar pull to match changing load conditions
<b>Steering</b>	Hydrostatic
<b>Service brake</b>	Hydrostatic (self-locking), wear-free
<b>Parking brake</b>	Multi-disk brake, wear-free, automatically applied with neutral joystick position
<b>Cooling system</b>	Hydraulic oil cooler integrated in combi radiator, hydro- static fan drive
<b>Filter system</b>	Micro cartridge filters in replenishing circuit
<b>Final drive</b>	Combination spur gear with planetary gear, double- sealed (duo cone seals) with temperature control
<b>Control</b>	Single joystick for all travel and steering functions. Optional: detented joystick, with inching pedal



## Operator's Cab

<b>Cab</b>	Resiliently mounted cab with positive pressure ventilation, can be tilted with hand pump 40° to the rear. With integrated ROPS Rollover Protective Structure (EN ISO 3471) and FOPS Falling Objects Protective Structure (EN ISO 3449)
<b>Operator's seat</b>	Air-suspended comfort seat, fully adjustable
<b>Monitoring</b>	Touch screen: display of current machine information, automatic monitoring of operating conditions. Individual setting of machine parameters

# Technical Data PR 736

## Undercarriage

	L	XL	LGP
<b>Design</b>	Undercarriage with rigid bottom rollers		
<b>Mounting</b>	Via separate pivot shafts and equalizer bar		
<b>Track chains</b>	Lubricated, single-grouser shoes, tensioning via a steel spring and grease tensioner		
<b>Links, each side</b>	41	45	45
<b>Track rollers, each side</b>	7	7	7
<b>Carrier rollers, each side</b>	2	2	2
<b>Sprocket segments, each side</b>	6	6	6
<b>Track shoes, standard</b>	610 mm/24"	610 mm/24"	711 mm/28" 812 mm/32"
<b>Track shoes, optional</b>	560 mm/22"	560 mm/22"	914 mm/36" 965 mm/38"

## Sound Emissions

<b>Operator sound exposure ISO 6396</b>	$L_{pA} = 75$ dB(A) (in the cab)
<b>Exterior sound pressure 2000/14/EC</b>	$L_{WA} = 111$ dB(A) (to the environment)

## Refill Capacities

<b>Fuel tank</b>	430 l/94.6 Imp.gal
<b>Diesel Exhaust Fluid (DEF) tank</b>	50 l/ 11 Imp.gal
<b>Cooling system</b>	41 l/ 9 Imp.gal
<b>Engine oil, with filter</b>	29 l/ 6.4 Imp.gal
<b>Splitter box</b>	5.5 l/ 1.2 Imp.gal
<b>Hydraulic tank</b>	111 l/24.4 Imp.gal
<b>Final drive L, XL (outside push frame), each side</b>	15 l/ 3.3 Imp.gal
<b>Final drive XL (inside push frame), each side</b>	22 l/ 4.8 Imp.gal
<b>Final drive LGP, each side</b>	26.5 l/ 5.8 Imp.gal

## Drawbar Pull

<b>Max.</b>	312 kN
<b>at 1.5 km/h/0.9 mph</b>	275 kN
<b>at 3.0 km/h/1.9 mph</b>	154 kN
<b>at 6.0 km/h/3.7 mph</b>	77 kN
<b>at 9.0 km/h/5.6 mph</b>	51 kN

# Dimensions PR 736

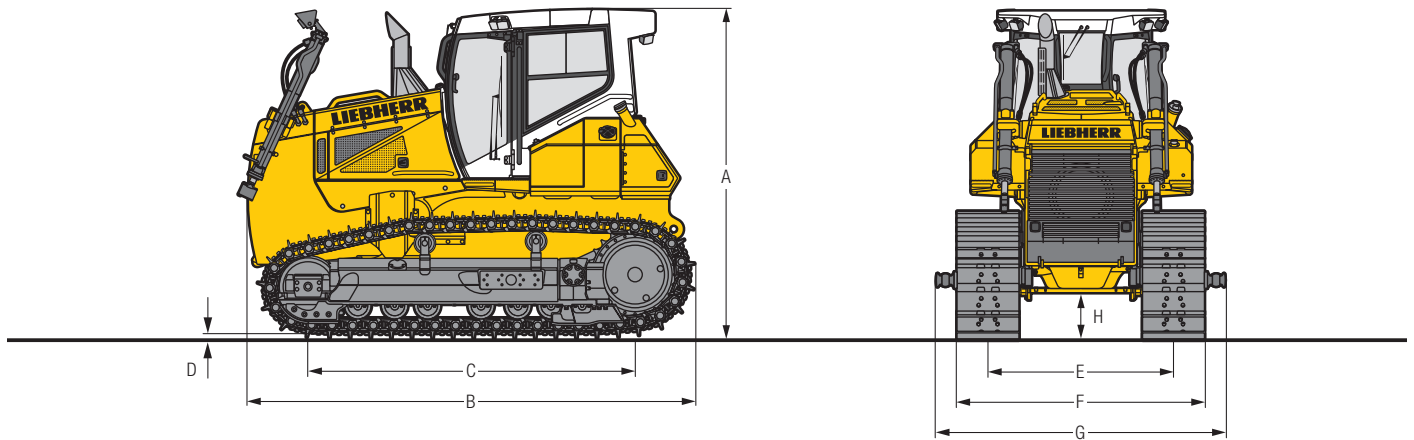

## Dimensions

Push frame		outside	inside	outside	inside	outside
Undercarriage		L	XL	XL	LGP	LGP
<b>A</b> Height over cab	mm ft in	3,248 10'8"		3,248 10'8"		3,248 10'8"
<b>B</b> Overall length without attachments	mm ft in	4,428 14'6"		4,428 14'6"		4,428 14'6"
<b>C</b> Length of track on ground	mm ft in	2,833 9'4"		3,237 10'7"		3,237 10'7"
<b>D</b> Height of grousers	mm in	65 2.5"		65 2.5"		65 2.5"
<b>H</b> Ground clearance	mm ft in	511 1'8"		511 1'8"		511 1'8"
<b>E</b> Track gauge	mm ft in	1,830 6'0"	2,180 7'2"	1,830 6'0"	2,290 7'6"	2,180 7'2"
<b>G</b> Width over trunnions	mm ft in	2,724 8'11"	–	2,724 8'11"	–	3,474 11'5"
<b>F</b> <b>Track shoes 560 mm / 22"</b>						
Width over tracks	mm / ft in	2,390 / 7'10"	2,740 / 9'	2,390 / 7'10"	–	–
Tractor shipping weight <sup>1)</sup>	kg / lb	17,571 / 38,737	18,196 / 40,115	18,271 / 40,281		
<b>F</b> <b>Track shoes 610 mm / 24"</b>						
Width over tracks	mm / ft in	2,440 / 8'0"	2,790 / 7'10"	2,440 / 8'0"	–	–
Tractor shipping weight <sup>1)</sup>	kg / lb	17,699 / 39,020	18,335 / 40,422	18,410 / 40,587		
<b>F</b> <b>Track shoes 711 mm / 28"</b>						
Width over tracks	mm / ft in	–	–	–	3,000 / 9'10"	–
Tractor shipping weight <sup>1)</sup>	kg / lb				18,634 / 41,081	
<b>F</b> <b>Track shoes 812 mm / 32"</b>						
Width over tracks	mm / ft in	–	–	–	3,102 / 10'2"	2,992 / 9'10"
Tractor shipping weight <sup>1)</sup>	kg / lb				18,913 / 41,696	19,156 / 42,232
<b>F</b> <b>Track shoes 914 mm / 36"</b>						
Width over tracks	mm / ft in	–	–	–	–	3,094 / 10'2"
Tractor shipping weight <sup>1)</sup>	kg / lb					19,452 / 42,884
<b>F</b> <b>Track shoes 965 mm / 38"</b>						
Width over tracks	mm / ft in	–	–	–	–	3,145 / 10'4"
Tractor shipping weight <sup>1)</sup>	kg / lb					19,604 / 43,219

<sup>1)</sup> Including coolant and lubricants, 20 % fuel, ROPS/FOPS cab.



# Front Attachments PR 736

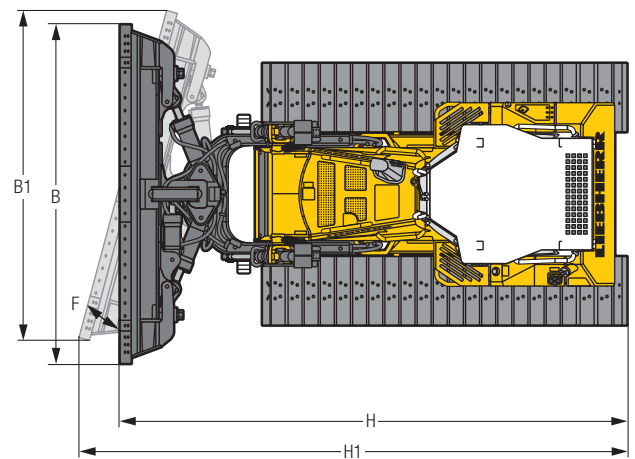
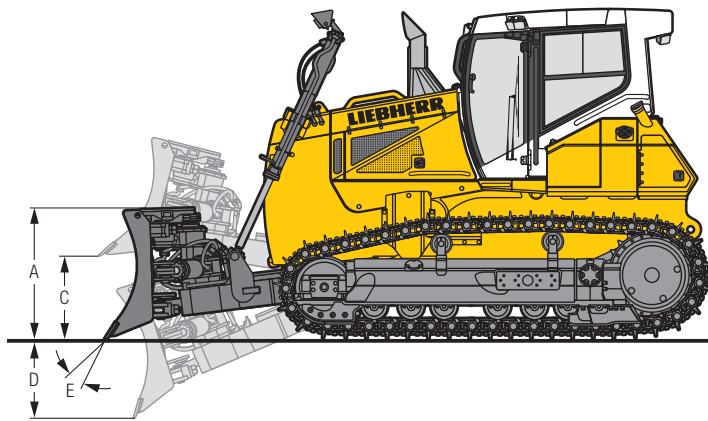

## 6-Way Blade with Inside Mounted Push Frame

		6-way blade	6-way blade with hinged corners	6-way blade	6-way blade with hinged corners
		XL	XL	LGP	LGP
<b>Undercarriage</b>		XL	XL	LGP	LGP
<b>Blade capacity, ISO 9246</b>	m <sup>3</sup>	4.67	4.67	4.63	4.63
	yd <sup>3</sup>	6.11	6.11	6.06	6.06
<b>A Height of blade</b>	mm	1,350	1,350	1,250	1,250
	ft in	4'5"	4'5"	4'1"	4'1"
<b>B Width of blade</b>	mm	3,638	3,638	4,029	4,029
	ft in	11'11"	11'11"	13'3"	13'3"
<b>B1 Width of blade, angled</b>	mm	3,413	3,413	3,781	3,781
	ft in	11'2"	11'2"	12'5"	12'5"
<b>Transport width</b>	mm	3,242	2,850	3,563	3,000 <sup>2)</sup>
	ft in	10'8"	9'4"	11'8"	9'10"
<b>C Lifting height</b>	mm	1,327	1,327	1,320	1,320
	ft in	4'4"	4'4"	4'4"	4'4"
<b>D Digging depth</b>	mm	679	679	675	675
	ft in	2'3"	2'3"	2'3"	2'3"
<b>E Blade pitch adjustment</b>		5°	5°	5°	5°
<b>F Blade angle adjustment</b>		20°	20°	20°	20°
<b>Max. blade tilt</b>	mm	545	545	606	606
	ft in	1'9"	1'9"	2'	2'
<b>H Overall length, blade straight</b>	mm	6,077	6,077	6,060	6,060
	ft in	19'11"	19'11"	19'11"	19'11"
<b>H1 Overall length, blade angled</b>	mm	6,655	6,655	6,707	6,707
	ft in	21'10"	21'10"	22'0"	22'0"
<b>Track shoes 560 mm / 22"</b>					
Operating weight <sup>1)</sup>	kg / lb	21,479 / 47,353	21,901 / 48,283	–	–
Ground pressure <sup>1)</sup>	kg/cm <sup>2</sup> / psi	0.59 / 8.39	0.60 / 8.53	–	–
<b>Track shoes 610 mm / 24"</b>					
Operating weight <sup>1)</sup>	kg / lb	21,618 / 47,659	22,040 / 48,590	–	–
Ground pressure <sup>1)</sup>	kg/cm <sup>2</sup> / psi	0.55 / 7.82	0.56 / 7.96	–	–
<b>Track shoes 711 mm / 28"</b>					
Operating weight <sup>1)</sup>	kg / lb	–	–	22,142 / 48,815	22,636 / 49,904
Ground pressure <sup>1)</sup>	kg/cm <sup>2</sup> / psi	–	–	0.48 / 6.83	0.49 / 6.97
<b>Track shoes 812 mm / 32"</b>					
Operating weight <sup>1)</sup>	kg / lb	–	–	22,421 / 49,430	22,915 / 50,519
Ground pressure <sup>1)</sup>	kg/cm <sup>2</sup> / psi	–	–	0.43 / 6.11	0.44 / 6.26

<sup>1)</sup> Including coolant and lubricants, 100 % fuel, ROPS/FOPS cab, operator, 6-way blade.

<sup>2)</sup> Transport width 3,000 mm only with max. 711 mm (28") track pads.

# Front Attachments PR 736

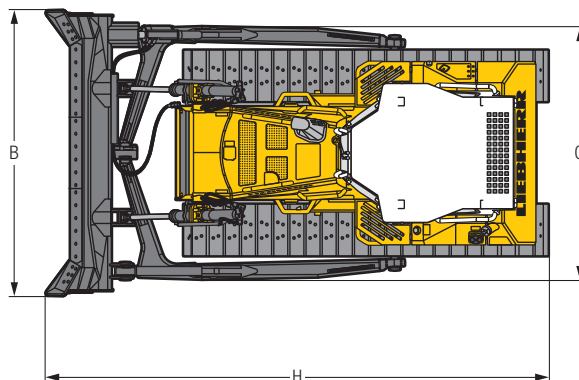
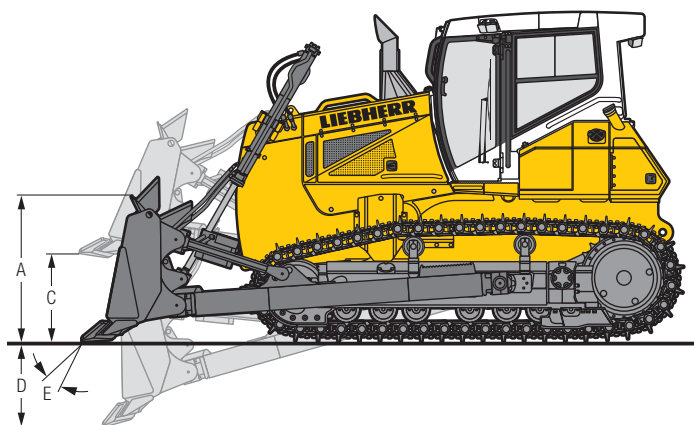

## Semi-U Blade and Straight Blade

		Semi-U blade	Semi-U blade	Straight blade
		L	XL	LGP
<b>Undercarriage</b>				
<b>Blade capacity, ISO 9246</b>	m <sup>3</sup>	5.56	5.56	4.10
	yd <sup>3</sup>	7.27	7.27	5.36
<b>A Height of blade</b>	mm	1,400	1,400	1,150
	ft in	4'7"	4'7"	3'9"
<b>B Width of blade</b>	mm	3,372	3,372	3,995
	ft in	11'1"	11'1"	13'1"
<b>C Lifting height</b>	mm	1,178	1,153	1,162
	ft in	3'10"	3'9"	3'10"
<b>D Digging depth</b>	mm	528	574	579
	ft in	1'9"	1'11"	1'11"
<b>E Blade pitch adjustment</b>		10°	10°	10°
<b>Max. blade tilt</b>	mm	432	432	395
	ft in	1'5"	1'5"	1'4"
<b>G Width over push frame</b>	mm	3,000	3,000	3,750
	ft in	9'10"	9'10"	12'4"
<b>H Overall length</b>	mm	5,751	5,970	5,709
	ft in	18'10"	19'7"	18'9"
<b>Track shoes 560 mm / 22"</b>				
Operating weight <sup>1)</sup>	kg / lb	20,511 / 45,219	21,040 / 46,385	–
Ground pressure <sup>1)</sup>	kg/cm <sup>2</sup> / psi	0.65 / 9.24	0.58 / 8.25	–
<b>Track shoes 610 mm / 24"</b>				
Operating weight <sup>1)</sup>	kg / lb	20,682 / 45,596	21,181 / 46,696	–
Ground pressure <sup>1)</sup>	kg/cm <sup>2</sup> / psi	0.60 / 8.53	0.54 / 7.68	–
<b>Track shoes 812 mm / 32"</b>				
Operating weight <sup>1)</sup>	kg / lb	–	–	22,411 / 49,408
Ground pressure <sup>1)</sup>	kg/cm <sup>2</sup> / psi	–	–	0.43 / 6.11
<b>Track shoes 914 mm / 36"</b>				
Operating weight <sup>1)</sup>	kg / lb	–	–	22,707 / 50,060
Ground pressure <sup>1)</sup>	kg/cm <sup>2</sup> / psi	–	–	0.38 / 5.40
<b>Track shoes 965 mm / 38"</b>				
Operating weight <sup>1)</sup>	kg / lb	–	–	22,859 / 50,395
Ground pressure <sup>1)</sup>	kg/cm <sup>2</sup> / psi	–	–	0.37 / 5.26

<sup>1)</sup> Including coolant and lubricants, 100 % fuel, ROPS/FOPS cab, operator, semi-U or straight blade.

# Rear Attachments PR 736



## 3-Shank Ripper

<b>A</b> Ripping depth (max./min.)	mm	512/362
	ft in	1'8" / 1'2"
<b>B</b> Lifting height (max./min.)	mm	676/526
	ft in	2'3" / 1'9"
<b>C</b> Additional length, attachment raised	mm	1,128
	ft in	3'8"
<b>D</b> Additional length, attachment lowered	mm	1,460
	ft in	4'9"
<b>E</b> Overall beam width	mm	2,320
	ft in	7'7"
<b>F</b> Distance between shanks	mm	1,000
	ft in	3'7"
Max. pitch adjustment		—
Weight	kg	1,919
	lb	4,231

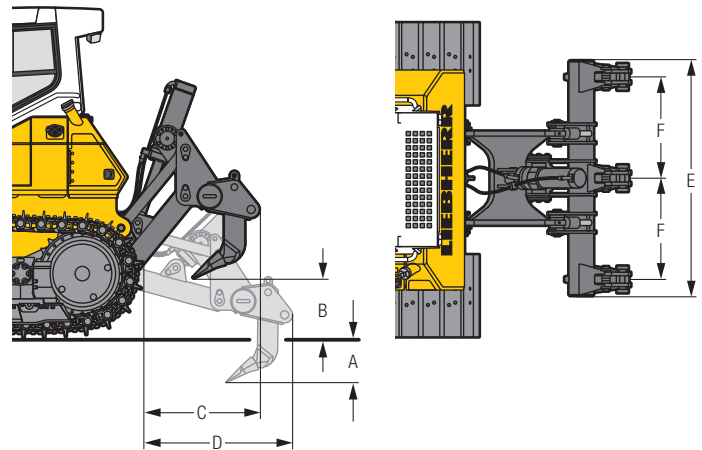

## Drawbar

<b>A</b> Additional length	mm	<b>rigid</b> 427
	ft in	1'5"
<b>B</b> Socket pin diameter	mm	50
	in	2"
<b>C</b> Height of jaw	mm	518
	ft in	1'8"
<b>D</b> Ground clearance	mm	430
	ft in	1'5"
Jaw opening	mm	95
	in	3.7"
Weight	kg	280
	lb	617

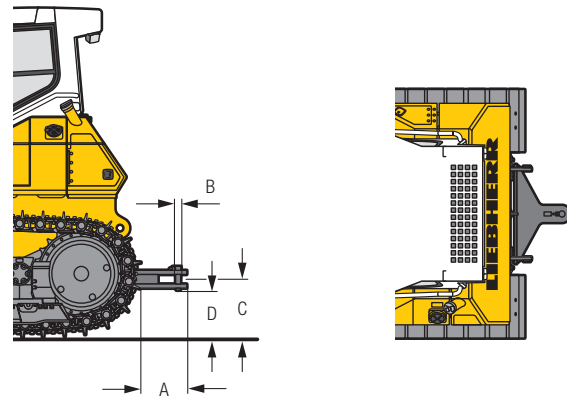

# Technical Data PR 746



## Engine

<b>Liebherr Diesel engine</b>	D 936 A7 Emission regulations according to 97/68/EC, 2004/26/EC Stage IV, EPA/CARB Tier 4f
<b>Rated power (net)</b>	
<b>ISO 9249</b>	185 kW/252 HP
<b>SAE J1349</b>	185 kW/248 HP
<b>Maximum power (net)</b>	
<b>ISO 9249</b>	210 kW/286 HP
<b>SAE J1349</b>	210 kW/281 HP
<b>Rated speed</b>	1,600 rpm
<b>Displacement</b>	10.5 l/641 in <sup>3</sup>
<b>Design</b>	6 cylinder in-line engine, water-cooled, turbocharged, air-to-air intercooler
<b>Injection system</b>	Direct fuel injection, Common Rail, electronic control
<b>Lubrication</b>	Pressurised lube system, engine lubrication guaranteed for inclinations up to 45°, on all sides
<b>Operating voltage</b>	24 V
<b>Alternator</b>	140 A
<b>Starter</b>	7.8 kW/11 HP
<b>Batteries</b>	2 x 180 Ah/12 V
<b>Air cleaner</b>	Dry-type air cleaner with pre-cleaner, main and safety elements, control light in the operator's cab
<b>Cooling system</b>	Combi radiator, comprising radiators for water and charge air. Hydrostatic fan drive



## Hydraulics

<b>Hydraulic system</b>	Load sensing (demand controlled)
<b>Pump type</b>	Swash plate piston pump
<b>Pump flow max.</b>	256 l/min./56.3 Imp.gpm
<b>Pressure limitation</b>	260 bar/3,770 psi
<b>Control valve</b>	2 circuits, expandable to 4
<b>Filter system</b>	Return filter with magnetic rod in the hydraulic tank
<b>Control</b>	Single joystick for all blade functions



## Travel Drive, Control

<b>Transmission system</b>	Infinitely variable hydrostatic travel drive, independent drive for each track
<b>Travel speed *</b>	Continuously variable
Speed range 1 (reverse):	0 – 4.0 km/h/2.5 mph (4.5 km/h/2.8 mph)
Speed range 2 (reverse):	0 – 6.0 km/h/3.7 mph (8.0 km/h/4.9 mph)
Speed range 3 (reverse):	0 – 11.0 km/h/6.8 mph (11.0 km/h/6.8 mph)
	* Travel speed ranges can be set on the travel joystick (memory function)
<b>Electronic system</b>	The electronic system automatically adjusts travel speed and drawbar pull to match changing load conditions
<b>Steering</b>	Hydrostatic
<b>Service brake</b>	Hydrostatic (self-locking), wear-free
<b>Parking brake</b>	Multi-disc brake, wear-free, automatically applied with neutral joystick position
<b>Cooling system</b>	Separate oil cooler, hydrostatic fan drive
<b>Filter system</b>	Micro cartridge filter in the replenishing circuit
<b>Final drive</b>	Combination spur gear with planetary gear, double- sealed (duo cone seals) with temperature indicator
<b>Control</b>	Proportional single joystick for all travel and steering functions



## Operator's Cab

<b>Cab</b>	Resiliently mounted cab with positive pressure ventilation, can be tilted with hand pump 40° to the rear. With integrated ROPS Rollover Protective Structure (EN ISO 3471) and FOPS Falling Objects Protective Structure (EN ISO 3449)
<b>Operator's seat</b>	Air suspended comfort seat, fully adjustable
<b>Monitoring</b>	Touch screen: display of current machine information, automatic monitoring of operating conditions, individual setting of machine parameters

# Technical Data PR 746

## Undercarriage

	L	LGP
<b>Design</b>	Undercarriage with rigid bottom rollers	
<b>Mounting</b>	Via separate pivot shafts and equalizer bar	
<b>Track chains</b>	Lubricated, single-grouser shoes, tensioning via steel spring and grease tensioner	
<b>Links, each side</b>	41	44
<b>Track rollers, each side</b>	7	8
<b>Carrier rollers, each side</b>	2	2
<b>Sprocket segments, each side</b>	6	6
<b>Track shoes, standard</b>	610 mm / 24"	812 mm / 32"
<b>Track shoes, optional</b>	560 mm / 22" 711 mm / 28"	914 mm / 36"



## Sound Emissions

<b>Operator sound exposure ISO 6396</b>	$L_{pA} = 75$ dB(A) (in the cab)
<b>Exterior sound pressure 2000/14/EC</b>	$L_{WA} = 112$ dB(A) (to the environment)



## Refill Capacities

<b>Fuel tank</b>	505 l / 111.1 Imp.gal
<b>Diesel Exhaust Fluid (DEF) tank</b>	56.5 l / 12.4 Imp.gal
<b>Cooling system</b>	49 l / 10.8 Imp.gal
<b>Engine oil, with filter</b>	43 l / 9.5 Imp.gal
<b>Splitter box</b>	8.5 l / 1.9 Imp.gal
<b>Hydraulic tank</b>	112 l / 24.6 Imp.gal
<b>Final drive L, each side</b>	17 l / 3.7 Imp.gal
<b>Final drive LGP, each side</b>	18 l / 4.0 Imp.gal



## Drawbar Pull

<b>Max.</b>	436 kN
<b>at 1.5 km/h / 0.9 mph</b>	385 kN
<b>at 3.0 km/h / 1.9 mph</b>	190 kN
<b>at 6.0 km/h / 3.7 mph</b>	95 kN
<b>at 9.0 km/h / 5.6 mph</b>	63 kN

# Dimensions PR 746

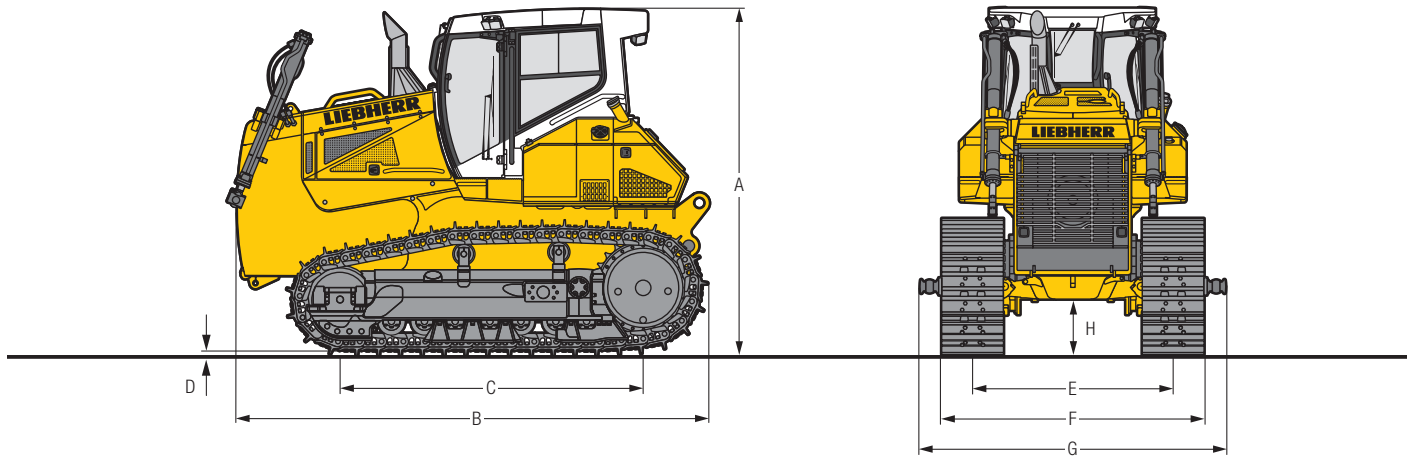

## Dimensions

Undercarriage		L	LGP
<b>A</b> Height over cab	mm	3,430	3,430
	ft in	11'3"	11'3"
<b>B</b> Overall length without attachments	mm	4,671	4,671
	ft in	15'4"	15'4"
<b>C</b> Length of track on ground	mm	2,999	3,323
	ft in	9'10"	10'11"
<b>D</b> Height of grousers	mm	71.5	71.5
	in	2.81"	2.81"
<b>H</b> Ground clearance	mm	551	551
	ft in	1'10"	1'10"
<b>E</b> Track gauge	mm	1,980	2,180
	ft in	6'6"	7'2"
<b>G</b> Width over trunnions	mm	3,000	3,600
	ft in	9'10"	11'10"
<b>Track shoes 560 mm / 22"</b>			
<b>F</b> Width over tracks	mm / ft in	2,540 / 8'4"	–
	Tractor shipping weight <sup>1)</sup> kg / lb	21,644 / 47,717	
<b>Track shoes 660 mm / 26"</b>			
<b>F</b> Width over tracks	mm / ft in	2,590 / 8'6"	–
	Tractor shipping weight <sup>1)</sup> kg / lb	21,998 / 48,497	
<b>Track shoes 711 mm / 28"</b>			
<b>F</b> Width over tracks	mm / ft in	2,691 / 8'10"	–
	Tractor shipping weight <sup>1)</sup> kg / lb	22,705 / 50,056	
<b>Track shoes 812 mm / 32"</b>			
<b>F</b> Width over tracks	mm / ft in	–	2,992 / 9'10"
	Tractor shipping weight <sup>1)</sup> kg / lb		22,769 / 50,197
<b>Track shoes 914 mm / 36"</b>			
<b>F</b> Width over tracks	mm / ft in	–	3,094 / 10'2"
	Tractor shipping weight <sup>1)</sup> kg / lb		23,344 / 51,465

<sup>1)</sup> Including coolant and lubricants, 20 % fuel, ROPS/FOPS cab.

# Front Attachments PR 746

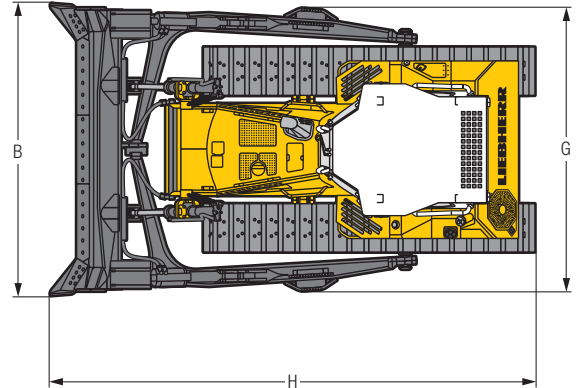
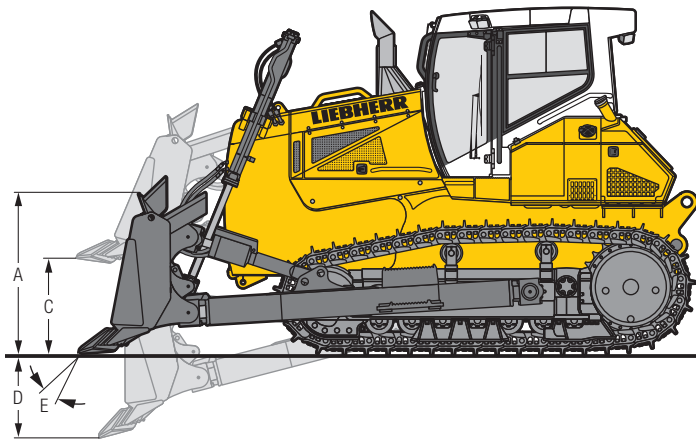

## Semi-U Blade and Straight Blade

		Semi-U blade	Straight blade <sup>2)</sup>
		L	LGP
<b>Undercarriage</b>			
<b>Blade capacity, ISO 9246</b>	m <sup>3</sup> yd <sup>3</sup>	7.20 9.42	6.00 7.85
<b>A Height of blade</b>	mm ft in	1,544 5'1"	1,320 4'4"
<b>B Width of blade</b>	mm ft in	3,690 12'1"	4,518 14'10"
<b>C Lifting height</b>	mm ft in	1,244 4'1"	1,185 3'11"
<b>D Digging depth</b>	mm ft in	515 1'8"	610 2'0"
<b>E Blade pitch adjustment</b>		10°	10°
<b>Max. blade tilt</b>	mm ft in	562 1'10"	567 1'10"
<b>G Width over push frame</b>	mm ft in	3,556 11'8"	4,034 13'3"
<b>H Overall length</b>	mm ft in	6,129 20'1"	5,955 19'6"
<b>Track shoes 560 mm / 22"</b>			
Operating weight <sup>1)</sup>	kg / lb	25,886 / 57,069	–
Ground pressure <sup>1)</sup>	kg/cm <sup>2</sup> / psi	0.77 / 10.95	–
<b>Track shoes 610 mm / 24"</b>			
Operating weight <sup>1)</sup>	kg / lb	26,240 / 57,849	–
Ground pressure <sup>1)</sup>	kg/cm <sup>2</sup> / psi	0.72 / 10.24	–
<b>Track shoes 711 mm / 28"</b>			
Operating weight <sup>1)</sup>	kg / lb	26,947 / 59,408	–
Ground pressure <sup>1)</sup>	kg/cm <sup>2</sup> / psi	0.63 / 8.96	–
<b>Track shoes 812 mm / 32"</b>			
Operating weight <sup>1)</sup>	kg / lb	–	27,257 / 60,091
Ground pressure <sup>1)</sup>	kg/cm <sup>2</sup> / psi	–	0.51 / 7.25
<b>Track shoes 914 mm / 36"</b>			
Operating weight <sup>1)</sup>	kg / lb	–	27,832 / 61,359
Ground pressure <sup>1)</sup>	kg/cm <sup>2</sup> / psi	–	0.46 / 6.54

<sup>1)</sup> Including coolant and lubricants, 100% fuel, ROPS/FOPS cab, operator, semi-U or straight blade.

<sup>2)</sup> Rear equipment or counterweight is recommended.

# Rear Attachments PR 746



## 1-Shank Ripper

Parallelogram		hydraulic pitch adjustment	
<b>A</b> Ripping depth (max./min.)	mm	900/570	
	ft in	2'11"/1'10"	
<b>B</b> Lifting height (max./min.)	mm	638/308	
	ft in	2'1"/1'0"	
<b>C</b> Additional length, attachment raised	mm	1,509	
	ft in	4'11"	
<b>D</b> Additional length, attachment lowered	mm	1,876	
	ft in	6'2"	
<b>E</b> Overall beam width	mm	1,360	
	ft in	4'6"	
<b>F</b> Distance between shanks	mm	-	
	ft in	-	
<b>Max. pitch adjustment</b>		25°	
<b>Weight</b>	kg	2,730	
	lb	6,019	

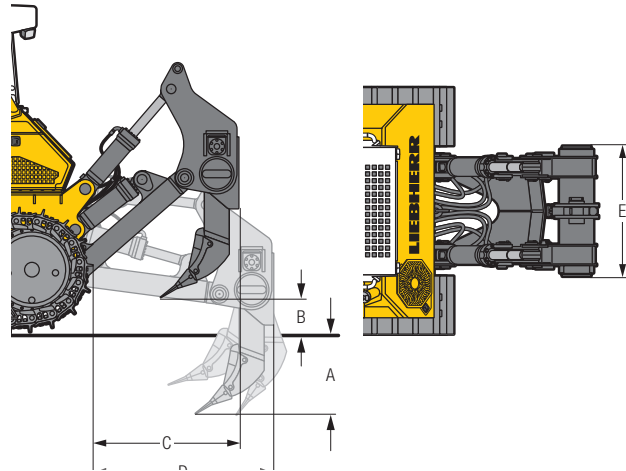

## 3-Shank Ripper

Parallelogram		standard	hydraulic pitch adjustment
<b>A</b> Ripping depth (max./min.)	mm	743/443	743/443
	ft in	2'5"/1'5"	2'5"/1'5"
<b>B</b> Lifting height (max./min.)	mm	759/461	765/465
	ft in	2'6"/1'6"	2'6"/1'6"
<b>C</b> Additional length, attachment raised	mm	1,511	1,494
	ft in	4'11"	4'11"
<b>D</b> Additional length, attachment lowered	mm	1,862	1,891
	ft in	6'1"	6'2"
<b>E</b> Overall beam width	mm	2,184	2,184
	ft in	7'2"	7'2"
<b>F</b> Distance between shanks	mm	1,000	1,000
	ft in	3'3"	3'3"
<b>Max. pitch adjustment</b>		-	25°
<b>Weight</b>	kg	3,323	3,334
	lb	7,326	7,350

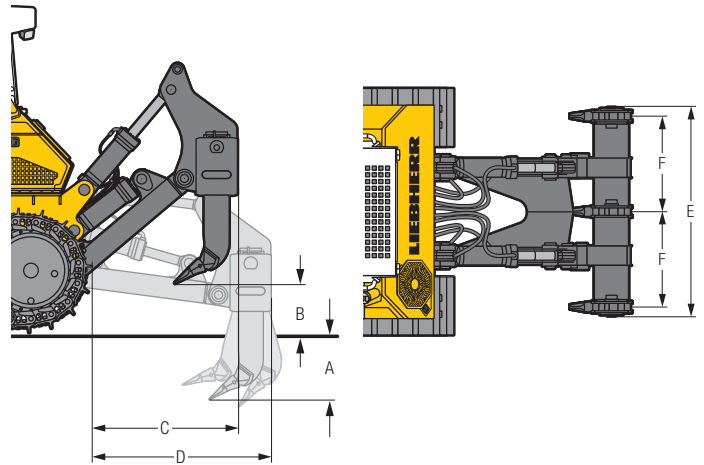



# Technical Data PR 756



## Engine

<b>Liebherr Diesel engine</b>	D 946 A7 Emission regulations according to 97/68/EC, 2004/26/EC stage IV, EPA/CARB Tier 4f
<b>Rated power (net)</b>	
<b>ISO 9249</b>	250 kW/340 HP
<b>SAE J1349</b>	250 kW/336 HP
<b>Maximum power (net)</b>	
<b>ISO 9249</b>	275 kW/374 HP
<b>SAE J1349</b>	275 kW/369 HP
<b>Rated speed</b>	1,600 rpm
<b>Displacement</b>	12 l/733 in <sup>3</sup>
<b>Design</b>	6 cylinder in-line engine, water-cooled, turbocharged, air-to-air intercooler
<b>Injection system</b>	Direct fuel injection, Common Rail, electronic control
<b>Lubrication</b>	Pressurised lube system, engine lubrication guaranteed for inclinations up to 45°, on all sides
<b>Operating voltage</b>	24 V
<b>Alternator</b>	140 A
<b>Starter</b>	7.8 kW/11 HP
<b>Batteries</b>	4 x 95 Ah/12 V
<b>Air cleaner</b>	Dry-type air cleaner with pre-cleaner, main and safety elements, control light in the operator's cab
<b>Cooling system</b>	Combi radiator, comprising radiators for water and charge air. Hydrostatic fan drive



## Hydraulics

<b>Hydraulic system</b>	Load sensing (demand-controlled)
<b>Pump type</b>	Swash plate piston pump
<b>Pump flow, max.</b>	256 l/min./56.3 Imp.gpm
<b>Pressure limitation</b>	260 bar/3,770 psi
<b>Control valve</b>	2 segments, expandable to 4
<b>Filter system</b>	Return filter with magnetic rod in the hydraulic tank
<b>Control</b>	Single joystick for all blade functions



## Travel Drive, Control

<b>Transmission system</b>	Infinitely variable hydrostatic travel drive, independent drive for each track
<b>Travel speed *</b>	Continuously variable
Speed range 1 (reverse):	0 – 4.0 km/h/2.5 mph (4.5 km/h/2.8 mph)
Speed range 2 (reverse):	0 – 6.0 km/h/3.7 mph (8.0 km/h/4.9 mph)
Speed range 3 (reverse):	0 – 11.0 km/h/6.8 mph (11.0 km/h/6.8 mph)
	* Travel speed ranges can be set on the travel joystick (memory function)
<b>Electronic system</b>	The electronic system automatically adjusts travel speed and drawbar pull to match changing load conditions
<b>Steering</b>	Hydrostatic
<b>Service brake</b>	Hydrostatic (self-locking), wear-free
<b>Parking brake</b>	Multi-disc brake, wear-free, automatically applied with neutral joystick position
<b>Cooling system</b>	Separate oil cooler, hydraulic fan drive
<b>Filter system</b>	Micro cartridge filter in replenishing circuit
<b>Final drive</b>	Combination spur gear with planetary gear, double- sealed (duo cone seals) with temperature indicator
<b>Control</b>	Single proportional joystick for all travel and steering functions



## Operator's Cab

<b>Cab</b>	Resiliently mounted cab with positive pressure ventilation, can be tilted with hand pump 40° to the rear. With integrated ROPS Rollover Protective Structure (EN ISO 3471) and FOPS Falling Objects Protective Structure (EN ISO 3449)
<b>Operator's seat</b>	Air suspended comfort seat, fully adjustable
<b>Monitoring</b>	Touch screen: display of current machine information, automatic monitoring of operating conditions, individual setting of machine parameters

# Technical Data PR 756

## Undercarriage

<b>Design</b>	Undercarriage with rigid bottom rollers or bogie suspension
<b>Mounting</b>	Via separate pivot shafts and equalizer bar
<b>Track chains</b>	Lubricated, single grouser shoes, tensioning via steel spring and grease tensioner
<b>Links, each side</b>	44
<b>Track rollers, each side</b>	7
<b>Carrier rollers, each side</b>	2
<b>Sprocket segments, each side</b>	5
<b>Track shoes, standard</b>	610 mm/24"
<b>Track shoes, optional</b>	560 mm/22", 711 mm/28"

## Sound Emissions

<b>Operator sound exposure ISO 6396</b>	$L_{pA} = 75$ dB(A) (in the cab)
<b>Exterior sound pressure 2000/14/EC</b>	$L_{WA} = 113$ dB(A) (to the environment)

## Refill Capacities

<b>Fuel tank</b>	660 l/ 145.2 Imp.gal
<b>Diesel Exhaust Fluid (DEF) tank</b>	80 l/ 17.6 Imp.gal
<b>Cooling system</b>	55 l/ 12.1 Imp.gal
<b>Engine oil, with filters</b>	43 l/ 9.5 Imp.gal
<b>Splitter box</b>	8.5 l/ 1.9 Imp.gal
<b>Hydraulic tank</b>	129 l/ 28.4 Imp.gal
<b>Final drive, each side</b>	20 l/ 4.4 Imp.gal

## Drawbar Pull

<b>Max.</b>	578 kN
<b>at 1.5 km/h / 0.9 mph</b>	510 kN
<b>at 3.0 km/h / 1.9 mph</b>	257 kN
<b>at 6.0 km/h / 3.7 mph</b>	128 kN
<b>at 9.0 km/h / 5.6 mph</b>	86 kN

# Dimensions PR 756

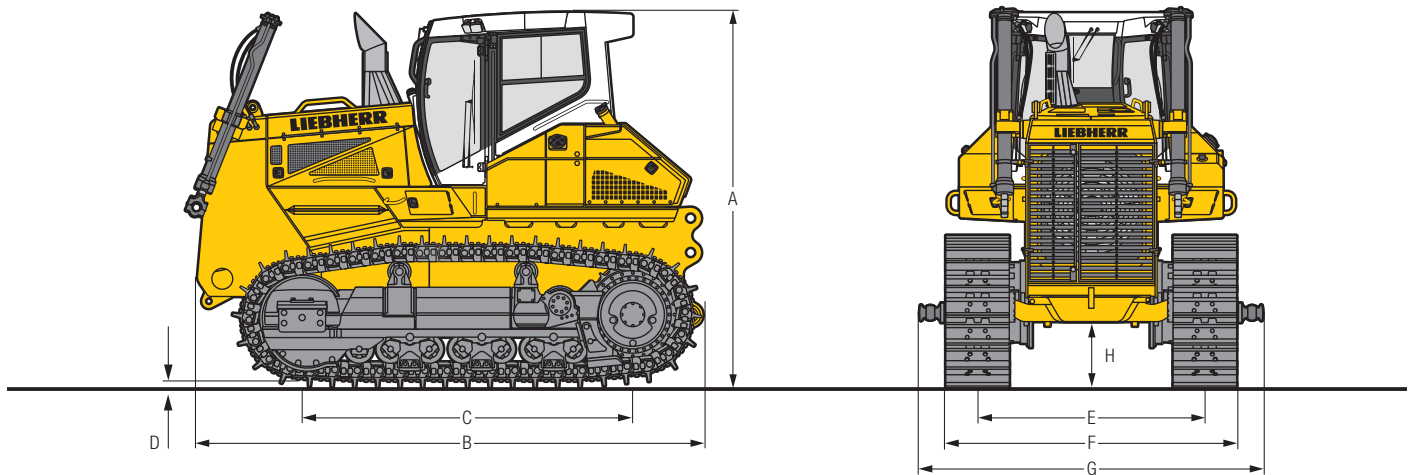

## Dimensions

Undercarriage		rigid bottom rollers	single bogie suspension
<b>A</b> Height over cab	mm		3,605
	ft in		11'10"
<b>B</b> Overall length without attachments	mm		4,885
	ft in		16'0"
<b>C</b> Length of track on ground	mm		3,174
	ft in		10'5"
<b>D</b> Height of grousers	mm		83
	in		3.27"
<b>H</b> Ground clearance	mm		635
	ft in		2'1"
<b>E</b> Track gauge	mm		2,180
	ft in		7'2"
<b>G</b> Width over trunnions	mm		3,145
	ft in		10'4"
<b>F</b> Track shoes 560 mm / 22"	mm / ft in		
	kg / lb	2,740 / 9'	2,740 / 9'
Tractor shipping weight <sup>1)</sup>	mm / ft in	28,806 / 63,506	29,733 / 65,550
	kg / lb		
<b>F</b> Track shoes 610 mm / 24"	mm / ft in		
	kg / lb	2,790 / 9'2"	2,790 / 9'2"
Tractor shipping weight <sup>1)</sup>	mm / ft in	29,046 / 64,035	29,973 / 66,079
	kg / lb		
<b>F</b> Track shoes 711 mm / 28"	mm / ft in		
	kg / lb	2,891 / 9'6"	2,891 / 9'6"
Tractor shipping weight <sup>1)</sup>	mm / ft in	29,523 / 65,087	30,450 / 67,131
	kg / lb		

<sup>1)</sup> Including coolant and lubricants, 20% fuel, ROPS/FOPS cab.

# Front Attachments PR 756

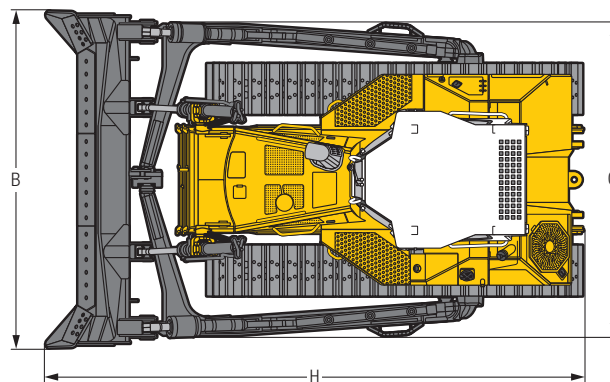
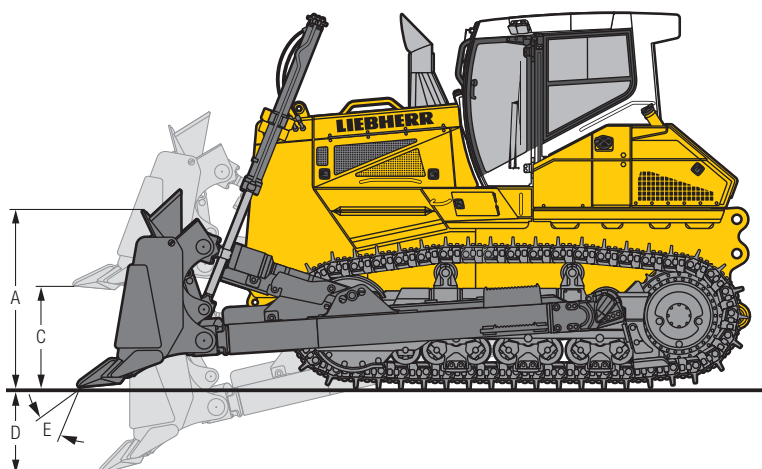

## Semi-U Blade

Undercarriage		rigid bottom rollers	single bogie suspension
<b>Blade capacity, ISO 9246</b>	m <sup>3</sup>		8.92
	yd <sup>3</sup>		11.67
<b>A Height of blade</b>	mm		1,650
	ft in		5'5"
<b>B Width of blade</b>	mm		4,044
	ft in		13'3"
<b>C Lifting height</b>	mm		1,372
	ft in		4'6"
<b>D Digging depth</b>	mm		570
	ft in		1'10"
<b>E Blade pitch adjustment</b>			10°
<b>Max. blade tilt</b>	mm		570
	ft in		1'10"
<b>G Width over push frame</b>	mm		3,776
	ft in		12'5"
<b>H Overall length</b>	mm		6,449
	ft in		21'2"
<b>Track shoes 560 mm / 22"</b>			
Operating weight <sup>1)</sup>	kg / lb	35,088 / 77,356	36,015 / 79,399
Ground pressure <sup>1)</sup>	kg/cm <sup>2</sup> / psi	0.99 / 14.08	1.01 / 14.36
<b>Track shoes 610 mm / 24"</b>			
Operating weight <sup>1)</sup>	kg / lb	35,328 / 77,885	36,255 / 79,928
Ground pressure <sup>1)</sup>	kg/cm <sup>2</sup> / psi	0.91 / 12.94	0.94 / 13.37
<b>Track shoes 711 mm / 28"</b>			
Operating weight <sup>1)</sup>	kg / lb	35,805 / 78,936	36,732 / 80,980
Ground pressure <sup>1)</sup>	kg/cm <sup>2</sup> / psi	0.79 / 11.23	0.81 / 11.52

<sup>1)</sup> Including coolant and lubricants, 100% fuel, ROPS/FOPS cab, semi-U blade, operator.

# Front Attachments PR 756

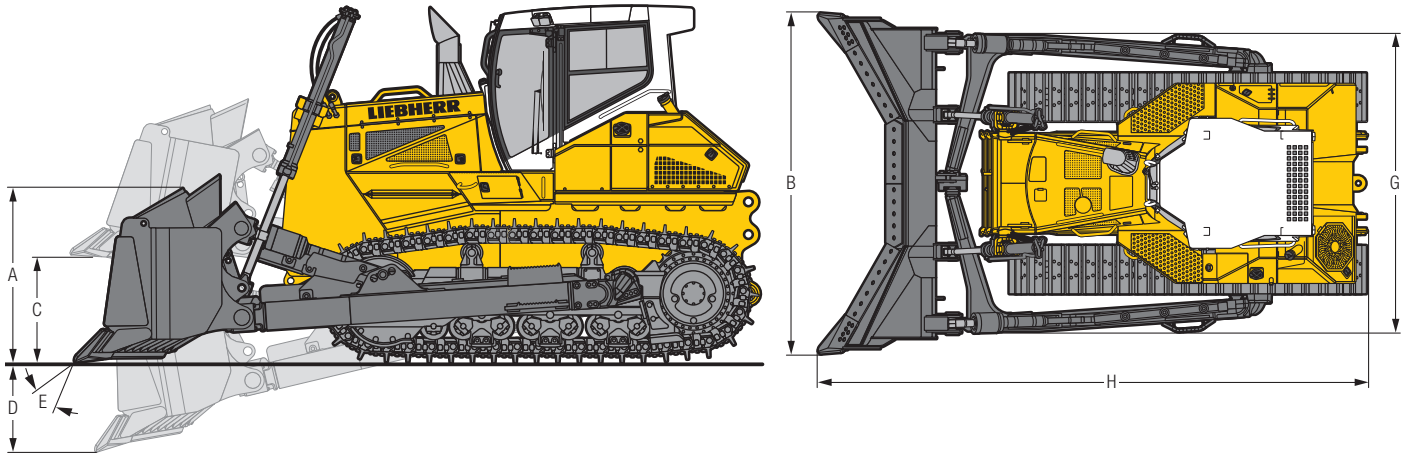

## U Blade

Undercarriage		rigid bottom rollers	single bogie suspension
<b>Blade capacity, ISO 9246</b>	m <sup>3</sup>	11.8	
	yd <sup>3</sup>	15.43	
<b>A Height of blade</b>	mm	1,700	
	ft in	5'7"	
<b>B Width of blade</b>	mm	4,281	
	ft in	14'1"	
<b>C Lifting height</b>	mm	1,360	
	ft in	4'6"	
<b>D Digging depth</b>	mm	566	
	ft in	1'10"	
<b>E Blade pitch adjustment</b>		10°	
<b>Max. blade tilt</b>	mm	604	
	ft in	2'	
<b>G Width over push frame</b>	mm	3,776	
	ft in	12'5"	
<b>H Overall length</b>	mm	6,872	
	ft in	22'7"	
<b>Track shoes 560 mm / 22"</b>			
Operating weight <sup>1)</sup>	kg / lb	35,058 / 77,290	35,985 / 79,333
Ground pressure <sup>1)</sup>	kg/cm <sup>2</sup> / psi	0.99 / 14.08	1.01 / 14.36
<b>Track shoes 610 mm / 24"</b>			
Operating weight <sup>1)</sup>	kg / lb	35,298 / 77,819	36,225 / 79,862
Ground pressure <sup>1)</sup>	kg/cm <sup>2</sup> / psi	0.91 / 12.94	0.94 / 13.37
<b>Track shoes 711 mm / 28"</b>			
Operating weight <sup>1)</sup>	kg / lb	35,775 / 78,870	36,702 / 80,914
Ground pressure <sup>1)</sup>	kg/cm <sup>2</sup> / psi	0.79 / 11.23	0.81 / 11.52

<sup>1)</sup> Including coolant and lubricants, 100% fuel, ROPS/FOPS cab, U blade, operator.

# Rear Attachments PR 756



## 1-Shank Ripper

Parallelogram		hydraulic pitch adjustment	
<b>A</b> Ripping depth (max./min.)	mm	1,203/423	
	ft in	3'11"/1'5"	
<b>B</b> Lifting height (max./min.)	mm	1,040/260	
	ft in	3'5"/0'10"	
<b>C</b> Additional length, attachment raised	mm	1,820	
	ft in	6'	
<b>D</b> Additional length, attachment lowered	mm	2,374	
	ft in	7'9"	
<b>E</b> Overall beam width	mm	1,370	
	ft in	4'6"	
<b>F</b> Distance between shanks	mm	-	
	ft in	-	
<b>Max. pitch adjustment</b>		31°	
<b>Max. penetration force</b>	kN	123.9	
	lbf	27,854	
<b>Max. pryout force</b>	kN	208.8	
	lbf	46,940	
<b>Weight</b>	kg	3,638	
	lb	8,020	

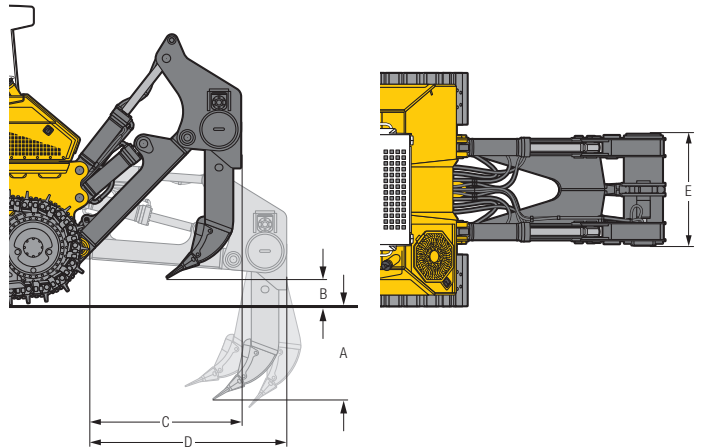

## 3-Shank Ripper

Parallelogram		hydraulic pitch adjustment	
<b>A</b> Ripping depth (max./min.)	mm	796/481	
	ft in	2'7"/1'7"	
<b>B</b> Lifting height (max./min.)	mm	982/667	
	ft in	3'3"/2'2"	
<b>C</b> Additional length, attachment raised	mm	1,820	
	ft in	6'	
<b>D</b> Additional length, attachment lowered	mm	2,373	
	ft in	7'9"	
<b>E</b> Overall beam width	mm	2,434	
	ft in	8'	
<b>F</b> Distance between shanks	mm	1,100	
	ft in	3'7"	
<b>Max. pitch adjustment</b>		31°	
<b>Max. penetration force</b>	kN	131.8	
	lbf	29,630	
<b>Max. pryout force</b>	kN	208.8	
	lbf	46,940	
<b>Weight</b>	kg	4,821	
	lb	10,628	

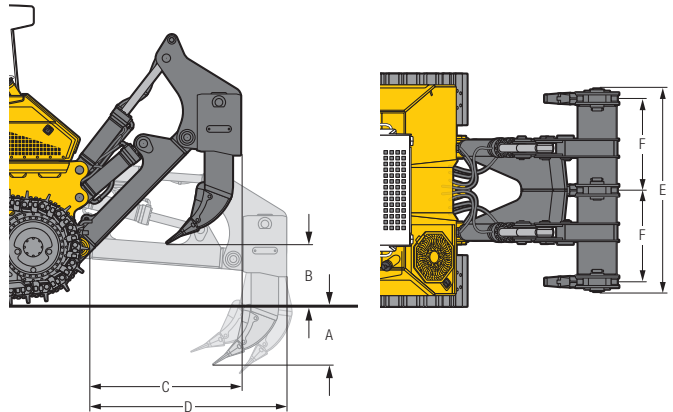

# Equipment

 <b>Base Machine</b>	736	746	756
Additional handle on cab footstep	+	+	+
Additional handle on fuel tank	+	+	+
Air filter with automatic dust ejector	+	+	+
Air filter, dry type, dual step, with pre-filter	•	•	•
Air pre-cleaner Top Air	+	+	+
Auto Idle	+	+	+
Automatic engine shut-off	+	+	+
Battery compartment, lockable	•	•	•
Coal arrangement	+	+	+
Cold environment arrangement	+	+	+
Cooling fan front, tilt-out	+	+	+
Cooling fan rear, tilt-out	-	•	•
Cooling fan, hydraulically driven	•	•	•
Cooling fan, reversible	+	+	+
Diesel Exhaust Fluid (DEF) tank, lockable	+	+	+
Engine compartment doors, lockable	•	•	•
Forestry arrangement	+	+	+
Fuel pre-filter	•	•	•
Fuel pre-filter, with electric heater	+	+	+
Fuel water separator	•	•	•
Fuel water separator, with electric heater	+	+	+
Grade control ready kit	+	1)	1)
Landfill arrangement	+	+	+
LiDAT – Data transmission system	•	•	•
Liebherr diesel engine emission stage IV/Tier 4f	•	•	•
Liebherr hydraulic oil, biologically degradable	+	+	+
Lugs for crane lifting, front	•	•	•
Lugs for crane lifting, rear	+	+	+
Radiator guard, heavy duty	+	+	+
Radiator guard, hinged	•	•	•
Radiator, wide-meshed	•	•	•
Refuelling pump, electric	+	+	+
Special paint scheme	+	+	+
Tool kit, basic	•	•	•
Tool kit, extended	+	+	+
Towing hitch rear	•	•	•
Towing lug front	•	•	•
Woodchip arrangement	+	+	+

 <b>Hydraulics System</b>	736	746	756
Blade float function	•	•	•
Blade quick drop function	•	•	•
Control block for 2 circuits	•	•	•
Hydraulic kit for ripper	+	+	+
Hydraulic kit for winch	+	+	+
Oil filter in hydraulic tank	•	•	•
Variable flow pump, load-sensing	•	•	•

 <b>Travel Drive</b>	736	746	756
Emergency stop	•	•	•
Final drives planetary gear	•	•	•
Inching brake pedal	+	•	•
Load limit control, electronic	•	•	•
Machine-release switch	•	•	•
Parking brake, automatic	•	•	•
Seat contact switch	•	•	•
Travel control, 3 speed ranges	•	•	•
Travel drive joystick, detended	+	+	+
Travel drive joystick, proportional	•	•	•
Travel drive, hydrostatic	•	•	•

 <b>Operator's Cab</b>	736	746	756
Additional control panel for air conditioning on side console	+	+	+
Air-conditioner	•	•	•
Armrests 3D adjustable	•	•	•
Cab heating	•	•	•
Coat hook	•	•	•
Dome light	•	•	•
Extension of cab door footstep	+	+	-
Fire extinguisher	+	+	+
Footrest on the right side of the front console	+	+	+
Joysticks, longitudinally adjustable	•	•	•
Operator's seat Comfort, air-suspended	•	•	•
Operator's seat Premium, air-suspended	+	+	+
Pressurised cab	•	•	•
Protective grid for rear window	+	+	+
Radio	+	+	+
Radio preparation kit	•	•	•
Rear-view camera	+	+	+
Rear-view mirror, inside	•	•	•
Rear-view mirrors, external	+	+	+
ROPS/FOPS integrated	•	•	•
Safety glass tinted	•	•	•
Sliding window left	•	•	•
Sliding window right	+	+	+
Socket 12 V	•	•	•
Stowage compartment, air-conditioned	•	•	•
Sun visor, front	+	+	+
Tilttable cab	•	•	•
Touch-controlled colour display	•	•	•
Windshield washer system	•	•	•
Windshield wipers front, rear, doors, with intermittent function	•	•	•

• = Standard, + = Option, - = not available, 1) on demand at your dealer

# Equipment

## Electrical System

	736	746	756
1 additional working light on each lift cylinder	+	+	+
1 additional working light on the ripper	-	-	+
1 working light on each lift cylinder	•	•	•
2 additional working light on the cab, rear	+	+	+
2 cold start batteries	•	•	•
2 working lights on the cab, rear	•	•	•
4 working light on the cab, front	•	•	•
All working lights in LED version	+	+	+
Back-up alarm	•	•	•
Back-up alarm, acoustic and visual	+	+	+
Back-up alarm, switchable	+	+	+
Battery main switch	•	•	•
Battery main switch, lockable	+	+	+
Beacon	+	+	+
Horn	•	•	•
Immobiliser, electronic	+	+	+
On-board voltage 24 V	•	•	•
Socket 24 V	•	•	•

## Undercarriage

	736	746	756
Master link, two-piece	•	•	•
Sprocket segments with recesses	+	+	+
Sprocket segments, bolted	•	•	•
Track frame, closed	•	•	•
Track guard, full length (with rigid bottom rollers)	+	+	+
Track guide (undercarriage with single bogie suspension)	-	-	•
Track guide centre part (with rigid bottom rollers)	+	+	+
Track guide, front and rear (with rigid bottom rollers)	•	•	•
Track pads with mud holes	+	+	+
Track shoes, heavy duty	<sup>1)</sup>	+	•
Track shoes, moderate service	•	•	-
Tracks, oil-lubricated	•	•	•
Undercarriage L	+	+	-
Undercarriage LGP	+	+	<sup>1)</sup>
Undercarriage with rigid bottom rollers	•	•	•
Undercarriage with rotary bushings FTB	+	-	-
Undercarriage with single-bogie suspension	-	-	+
Undercarriage XL	+	-	+

• = Standard, + = Option, - = not available, <sup>1)</sup> on demand at your dealer

Options and/or special attachments, supplied by vendors other than Liebherr, are only to be installed with the knowledge and approval of Liebherr in order to retain warranty.

## Attachments Front

	736	746	756
6-way blade	+	-	-
6-way blade with hinged corners	+	-	-
Guards for hydraulic cylinders, 6-way blade	+	-	-
Guards for hydraulic cylinders, semi-U blade	-	-	+
Hydraulic pitch angle adjustment	-	+	+
Mechanical angle blade	+	+	+
Semi-U blade	+	+	+
Spill plate	+	+	+
Straight blade	+	+	<sup>1)</sup>
Trash rack	+	+	+
U blade	<sup>1)</sup>	<sup>1)</sup>	+
Wear plates on push frame	+	+	+
Wear plates on semi-U blade	+	+	+

## Attachments Rear

	736	746	756
Counterweight, rear	+	+	+
Drawbar rear, rigid	+	+	+
Mounting plate for third-party arrangement	+	+	+
Ripper, 1 shank	+	+	+
Ripper, 1 shank with hydraulic pin puller	-	-	+
Ripper, 3 shank	+	+	+
Winch	+	+	+

### Liebherr-Werk Telfs GmbH

Hans Liebherr-Straße 35, A-6410 Telfs

☎ +43 50809 6-100, Fax +43 50809 6-7772

www.liebherr.com, E-Mail: lwt.marketing@liebherr.com

www.facebook.com/LiebherrConstruction