



## RX 20 Technical Data Electric Forklift Truck

---

[RX 20-14](#)

[RX 20-15](#)

[RX 20-16](#)

[RX 20-18](#)

[RX 20-20](#)



This specification sheet to VDI Guideline 2198 only gives the technical figures for the standard truck.  
Different tyres, other masts, additional equipment etc. could give different figures.

Characteristics			STILL	STILL	STILL	STILL	STILL	STILL	STILL	STILL	STILL
1.1	Manufacturer		RX 20-14	RX 20-15	RX 20-16	RX 20-16P	RX 20-18	RX 20-18P/h	RX 20-20	RX 20-20 P	RX 20-20 P/h
1.2	Manufacturer's model designation		6209	6210	6211	6212	6213	6214	6215	6216	6217
1.2.1	Type designation of the manufacturer		Electric	Electric	Electric	Electric	Electric	Electric	Electric	Electric	Electric
1.3	Power supply		Rider seated	Rider seated	Rider seated	Rider seated	Rider seated	Rider seated	Rider seated	Rider seated	Rider seated
1.4	Type of control		Q	kg	1400	1500	1600	1600	1800	2000	2000
1.5	Carrying capacity/load		c	mm	500	500	500	500	500	500	500
1.6	Load Centre		x	mm	355	355	355	355	355	365	365
1.8	Load distance		y	mm	1341	1341	1341	1410	1441	1540	1448
1.9	Wheelbase										
2.1	Weight										
2.2	Axle loadings laden front										
2.2	Axle loadings laden rear										
2.3	Axle loadings unladen front										
2.3	Axle loadings unladen rear										
3.1	Tyres - rubber (V), superelastic (SE), pneumatic (L), polyurethane (PE)										
3.2	Tyre size - front										
3.3	Tyre size - rear										
3.5	Wheels - number front (x = drive wheel)										
3.5	Wheels - number rear (x = drive wheel)										
3.6	Track width - front	b <sub>10</sub>	mm	932	932	932	932	942	942	942	942
3.7	Track width - rear	b <sub>11</sub>	mm	168	168	168	865	168	865	168	865
4.1	Tilt angle, mast/fork carriage forwards		°	3	3	3	3	3	3	3	3
4.1	Tilt angle, mast/fork carriage backwards		°	8	8	8	8	8	8	8	8
4.2	Closed height	h <sub>1</sub>	mm	2160	2160	2160	2160	2160	2160	2160	2160
4.3	Free lift	h <sub>2</sub>	mm	150	150	150	150	150	150	150	150
4.4	Lift height*	h <sub>3</sub>	mm	3230	3230	3230	3230	3230	3150	3150	3150
4.5	Height, mast raised	h <sub>4</sub>	mm	3805	3805	3805	3805	3805	3805	3805	3805
4.7	Height to top of overhead guard (cabin)	h <sub>6</sub>	mm	2082	2082	2082	2082	2240	2082	2082	2240
4.8	Seat height relative to SIP	h <sub>7</sub>	mm	1015	1015	1015	1015	1173	1015	1015	1173
4.12	Coupling height	h <sub>10</sub>	mm	490	490	490	460/350	490	460/350	490	460/350
4.19	Overall length	l <sub>1</sub>	mm	2683	2683	2683	2861	2783	2908	2892	2930
4.20	Length to front face of forks	l <sub>2</sub>	mm	1883	1883	1883	2061	1983	2108	2092	2130
4.21	Overall width	b <sub>1</sub>	mm	1099	1099	1099	1138	1138	1138	1138	1138
4.22	Fork thickness	s	mm	40	40	40	40	40	40	40	40
4.22	Fork width	e	mm	80	80	80	80	80	80	80	80
4.22	Fork length	l	mm	800	800	800	800	800	800	800	800
4.23	Fork carriage to ISO 2328 - class/form A or B			ISO II/A	ISO II/A	ISO II/A	ISO II/A	ISO II/A	ISO II/A	ISO II/A	ISO II/A
4.24	Fork carriage width	b <sub>3</sub>	mm	980	980	980	980	980	980	980	980
4.31	Ground clearance beneath mast, laden	m <sub>1</sub>	mm	90	90	90	90	90	90	90	90
4.32	Ground clearance at centre of wheelbase	m <sub>2</sub>	mm	123	123	123	123	123	123	123	123
4.34.1	Aisle width for pallets 1000 x 1200 wide	A <sub>st</sub>	mm	3209	3209	3209	3408	3309	3439	3418	3473
4.34.2	Aisle width for pallets 800 x 1200 long	A <sub>st</sub>	mm	3333	3333	3333	3607	3433	3638	3542	3672
4.35	Outer turning radius	W <sub>a</sub>	mm	1528	1528	1528	1852	1628	1883	1727	1907
4.36	Inner turning radius	b <sub>13</sub>	mm	-	-	-	533	-	538.5	-	541
5.1	Speed laden		km/h	16	16	16	16	16	16	16	16
5.1	Speed unladen		km/h	16	16	16	16	16	16	16	16
5.2	Lift speed laden		m/s	0.43	0.43	0.43	0.43	0.42	0.42	0.38	0.38
5.2	Lift speed unladen		m/s	0.60	0.60	0.60	0.60	0.60	0.60	0.52	0.52
5.3	Lowering speed laden		m/s	0.51	0.51	0.51	0.51	0.52	0.52	0.53	0.53
5.3	Lowering speed unladen		m/s	0.47	0.47	0.47	0.47	0.48	0.48	0.49	0.49
5.5	Rated drawbar pull laden		N	3200	3200	3200	3200	3050	2980	2980	2970
5.5	Rated drawbar pull unladen		N	3340	3340	3340	3340	3320	3260	3280	3280
5.6	Max. drawbar pull laden		N	9260	9260	9260	9250	8990	8950	8950	8920
5.6	Max. drawbar pull unladen		N	9120	9120	9120	9120	9130	9080	9100	9070
5.7	Gradeability laden		%	13.5	12.8	12.8	12.7	11.4	10.7	10.5	10.5
5.7	Gradeability unladen		%	20.1	20.1	20.1	19.9	19.0	17.1	17.9	17.8
5.8	Max. gradeability laden		%	21.8	21.2	21.2	21.0	19.0	17.8	17.6	17.5
5.8	Max. gradeability unladen		%	24.8	24.8	24.8	25.4	25.9	26.4	27.2	25.2
5.9	Acceleration time laden		s	4.1	4.1	4.1	4.1	4.2	4.3	4.3	4.4
5.9	Acceleration time unladen		s	4.0	4.0	4.0	4.0	4.0	4.1	4.1	4.2
5.10	Brakes			elect./mech.	elect./mech.	elect./mech.	elect./mech.	elect./mech.	elect./mech.	elect./mech.	elect./mech.
6.1	Drive motor, output S2 60 min		kW	2 x 4.5	2 x 4.5	2 x 4.5	2 x 4.5	2 x 4.5	2 x 4.5	2 x 4.5	2 x 4.5
6.2	Hoist motor capacity at 20% duty factor		kW	9	9	9	9	9	9	9	9
6.3	Battery equipment to DIN 43531/35/36 A, B, C, no			DIN 43531 B	DIN 43531 B	DIN 43531 B	DIN 43531 B	DIN 43531 B	DIN 43531 B	DIN 43531 B	DIN 43531 B
6.4	Battery voltage	U	V	48	48	48	48	48	48	48	48
6.4.1	Battery capacity	K <sub>5</sub>	Ah	575 (-625)	575 (-625)	575 (-625)	575 (-625)	700 (-800)	575 (-625)	575 (-625)	700 (-800)
6.5	Battery weight		kg	856	856	856	856	1119	856	856	1119
6.6	Energy consumption 60 VDI work cycles/hour		kWh/h	4.2	4.3	4.4	4.4	4.7	5.2	5.0	5.4
10.1	Working pressure for attachments		bar	250	250	250	250	250	250	250	250
10.2	Oil flow for attachments		l/min	30	30	30	30	30	30	30	30
10.7	Noise pressure level LpAZ (cockpit)***		dB (A)	<70	<70	<70	<70	<70	<70	<70	<70
	Human vibration: acceleration as per EN13059		m/s <sup>2</sup>	<0,7	<0,7	<0,7	<0,7	<0,7	<0,7	<0,7	<0,7
10.8	Trailer coupling, type/DIN			Bolt	Bolt	Bolt	Bolt	Bolt	Bolt	Bolt	Bolt

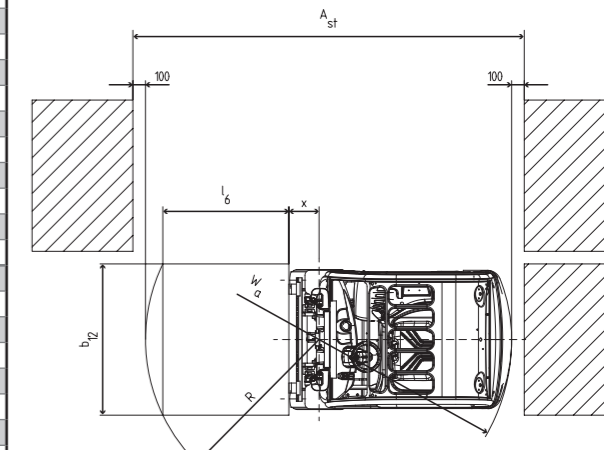
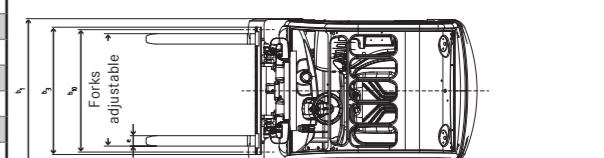
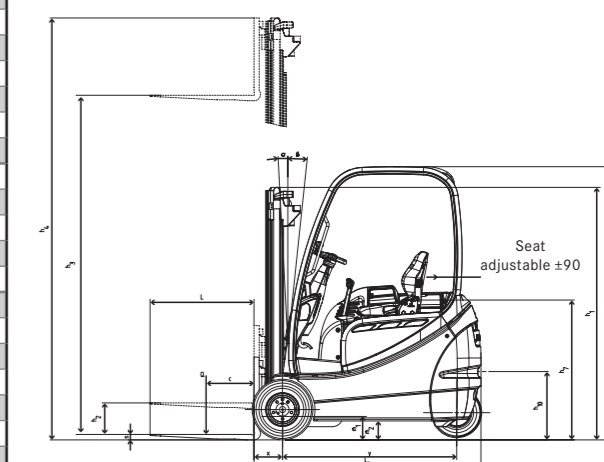



Dimensions relate to a vertical mast

\* The specified rated lift takes into consideration the tyre deflection and the tolerances of the tyre diameter.  
\*\*\* Without cab. Different values with cab.

				Telescopic-mast		HiLo - mast		Triplex - mast	
RX 20-14/15/16	Rated lift	h <sub>3</sub>	mm	2830-4230	4730-5430	2975-3975	4320-5220	5620-7870	
	Closed height	h <sub>1</sub>	mm	1960-2660	2910-3260	1960-2460	1960-2260	2460-3210	
	Free lift	h <sub>2</sub> /h <sub>5</sub>	mm	150	150	1362-1862	1362-1662	1862-2612	
	Overall height	h <sub>4</sub>	mm	3473-4873	5273-6073	3593-4593	4938-5838	6238-8488	
	Forward tilt	a	°	3					
	Back tilt	b	°	8		6			
	Fork location centre - centre		mm	216 368 445 521 673 670					
	Greatest width	B	mm	1099	1188	1099	1099	1188	
	Overall length	L <sub>2</sub>	mm	1883			1903		
	Load distance	x	mm	355			375		
	Working aisle width	A <sub>st</sub>	mm	(1000 x 1200) 3209 (1200 x 800) 3333			(1000 x 1200) 3228 (1200 x 800) 3353		
	Tyres	v		18 x 7-8	200/50-10	18 x 7-8	18 x 7-8	200/50-10	
	Tyres	h		15 x 4 1/2-8					
	Track	v/h	mm	932/168	990/168	932/168	932/168	990/168	
	RX 20-16P	Overall length	L <sub>2</sub>	2061			2081		
		Working aisle width	A <sub>st</sub>	(1000 x 1200) 3408 (1200 x 800) 3607			(1000 x 1200) 3428 (1200 x 800) 3627		
Tyres		v/h	18 x 7-8 / 16 x 6-8						
Track		v/h	mm	932/865	990/865	932/865	932/865	990/865	
RX 20-18	Rated lift	h <sub>3</sub>	mm	2830-4230	4730-5430	2875-3875	4170-5070	5470-7720	
	Closed height	h <sub>1</sub>	mm	1960-2660	2910-3260	1960-2460	1960-2260	2460-3210	
	Free lift	h <sub>2</sub> /h <sub>5</sub>	mm	150	150	1312-1812	1312-1612	1812-2562	
	Overall height	h <sub>4</sub>	mm	3473-4873	5273-6073	3543-4543	4838-5738	6138-8388	
	Forward tilt	a	°	3					
	Back tilt	b	°	8		6			
	Greatest width	B	mm	1138	1188	1138	1138	1188	
	Overall length	L <sub>2</sub>	mm	1983			2003		
	Load distance	x	mm	355			375		
	Working aisle width	A <sub>st</sub>	mm	(1000 x 1200) 3309 (1200 x 800) 3433			(1000 x 1200) 3327 (1200 x 800) 3452		
	Tyres	v/h		200/50-10 / 16 x 6-8					
	Track	v/h	mm	942/168	990/168	942/168	942/168	990/168	
	RX 20-18P/h	Overall length	L <sub>2</sub>	2108			2128		
		Working aisle width	A <sub>st</sub>	(1000 x 1200) 3439 (1200 x 800) 3638			(1000 x 1200) 3459 (1200 x 800) 3658		
		Tyres	v/h	200/50-10 / 16 x 6-8					
		Track	v/h	mm	942/865	990/865	942/865	942/865	990/865
RX 20-20	Rated lift	h <sub>3</sub>	mm	2750-4150	4630-5330	2870-3870	4165-5065	5665-7915	
	Closed height	h <sub>1</sub>	mm	1960-2660	2910-3260	1960-2460	1960-2260	2460-3210	
	Free lift	h <sub>2</sub> /h <sub>5</sub>	mm	150	150	1405-1905	1405-1705	1905-2655	
	Overall height	h <sub>4</sub>	mm	3325-4725	5225-5925	3445-4445	4755-5655	6255-8505	
	Forward tilt	a	°	3					
	Backward tilt	b	°	8		6			
	Greatest width	B	mm	1138	1188	1138	1138	1188	
	Overall length	L <sub>2</sub>	mm	2092			2114		
	Load distance	x	mm	365			387		
	Working aisle width	A <sub>st</sub>	mm	(1000 x 1200) 3418 (1200 x 800) 3542			(1000 x 1200) 3438 (1200 x 800) 3563		
	Tyres	v/h		200/50-10 / 16 x 6-8					
	Track	v/h	mm	942/168	990/168	942/168	942/168	990/168	
	RX 20-20P	Overall length	L <sub>2</sub>	2130			2152		
		Working aisle width	A <sub>st</sub>	(1000 x 1200) 3473 (1200 x 800) 3672			(1000 x 1200) 3495 (1200 x 800) 3694		
		Tyres	v/h	200/50-10 / 16 x 6-8					
		Track	v/h	mm	942/865	990/865	942/865	942/865	990/865
RX 20-20Ph	Overall length	L <sub>2</sub>	2118			2140			
	Working aisle width	A <sub>st</sub>	(1000 x 1200) 3449 (1200 x 800) 3648			(1000 x 1200) 3471 (1200 x 800) 3670			
	Tyres	v/h	200/50-10 / 16 x 6-8						
	Track	v/h	mm	942/865	990/865	942/865	942/865	990/865	

### Gradients, maximum distance that can be driven in 60 minutes.:

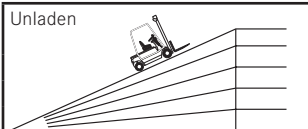
Example: An RX 20-16 with a load of 1600 kg and a gradient of 13% can drive a distance of 290 m 10 times per hour.

Unladen		RX 20-16	RX 20-16 P	RX 20-18 P/h	RX 20-20 P/h
	4,7%	15809	15800	15788	15774
	10,5%	5343	5340	5200	5328
	20,1%	3042	3040	3032	2463
	24,8%	1696	1696	1537	1371
	2,0%	15068	15073	15412	15354
	6,0%	5093	5095	4980	4642
	13,0%	2900	2900	2548	2289
	16,7%	2122	1516	1438	1346
	21,2%	1327	1327		

(Dry rough concrete surface = Coefficient of friction 0.80) (Standard battery as indicated in data sheet)

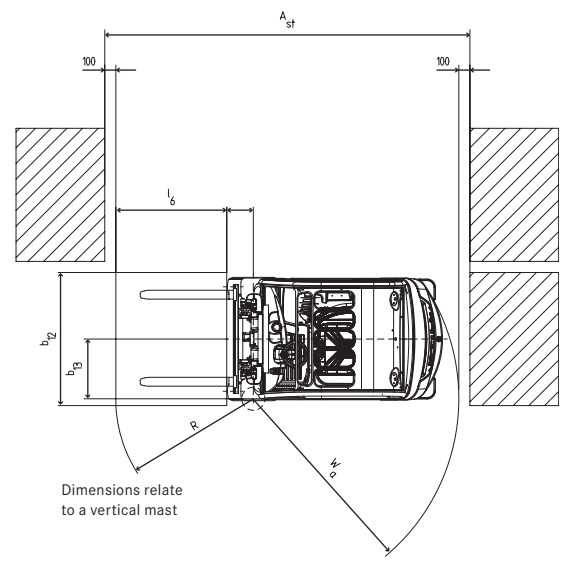
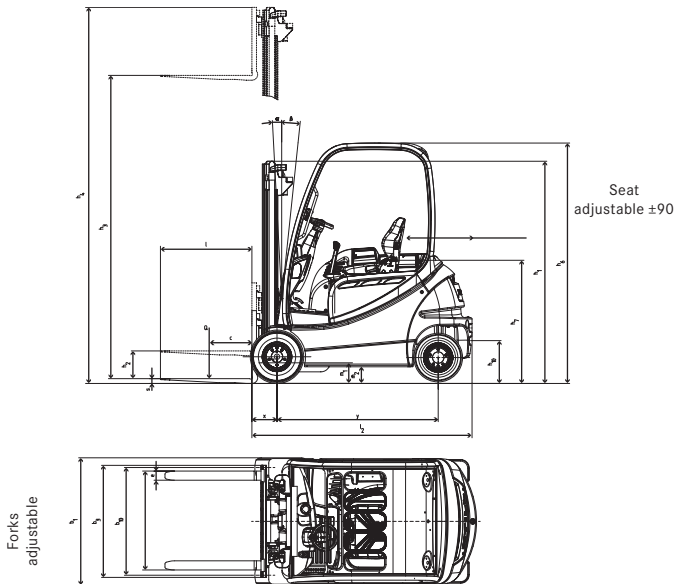

— Fork carriage    - - - - Hook-on sideshift

Capacities RX 20-14 Tele-/ HiLo - mast

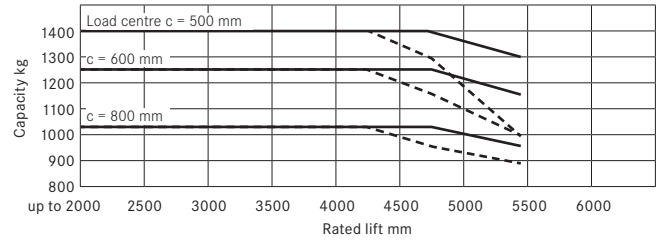

Capacities RX 20-14 Triplex mast

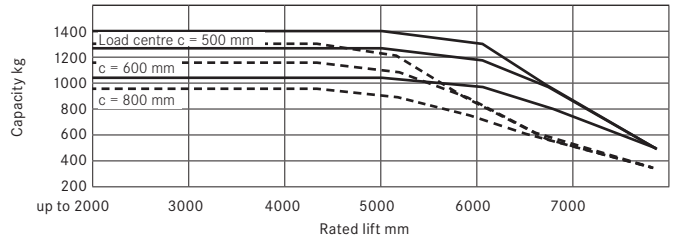

Capacities RX 20-15 Tele-/ HiLo - mast

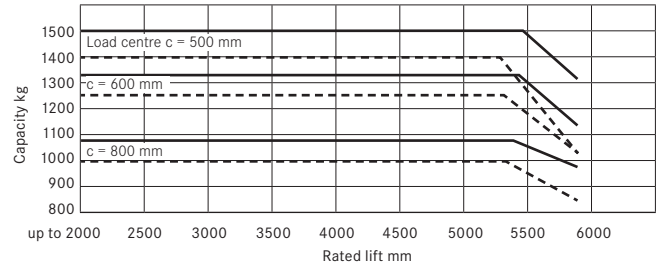

Capacities RX 20-15 Triplex mast

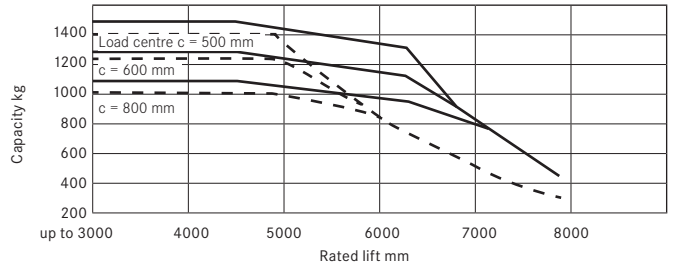

Capacities RX 20-16 Tele-/ HiLo - mast

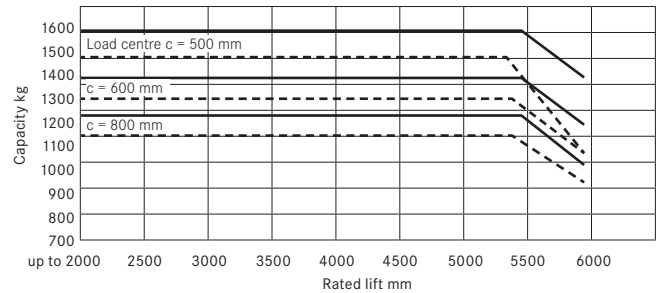

Capacities RX 20-16 Triplex mast

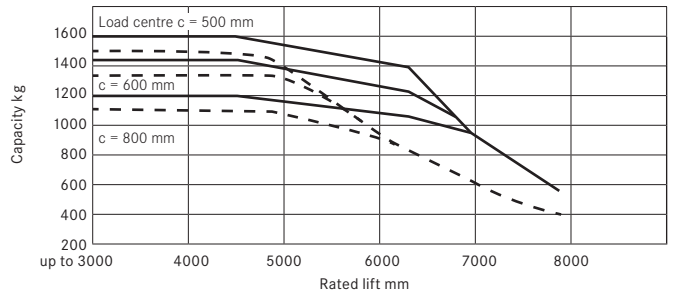

Capacities RX 20-16P Tele-/ HiLo - mast

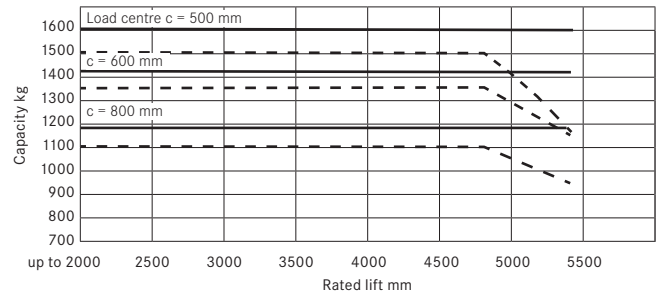

Capacities RX 20-16P Triplex mast

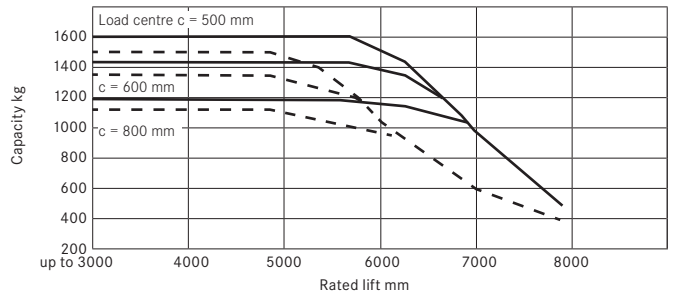

Capacities RX 20-18 Tele-/ HiLo - mast

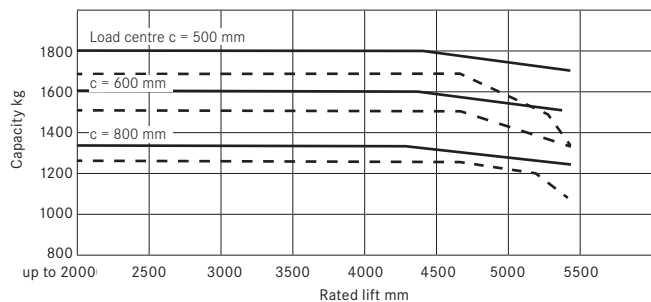

Capacities RX 20-18 Triplex mast

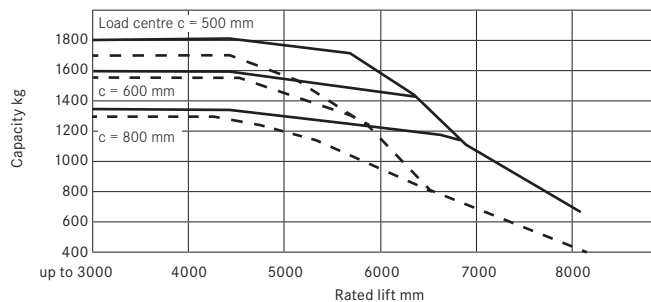

Capacities RX 20-18P/h Tele-/ HiLo - mast

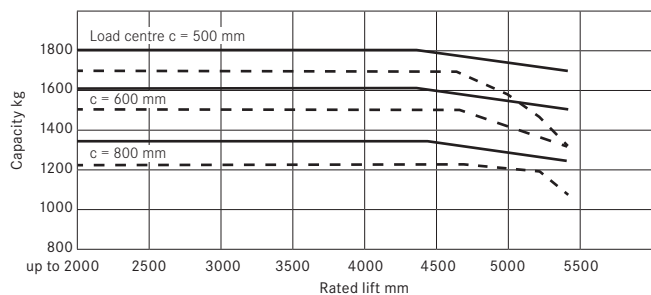

Capacities RX 20-18P/h Triplex mast

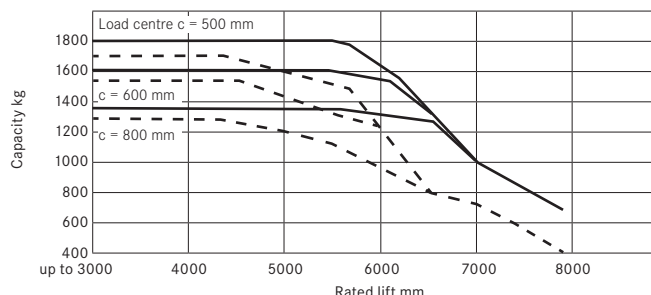

Capacities RX 20-20 Tele-/ HiLo - mast

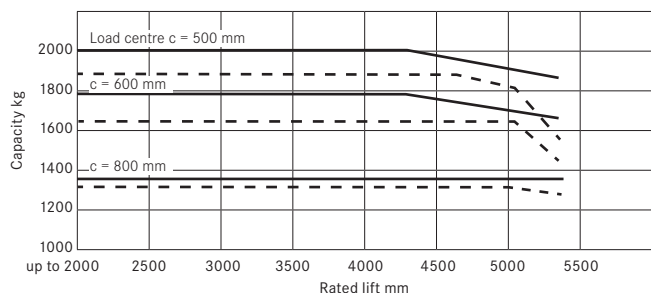

Capacities RX 20-20 Triplex mast

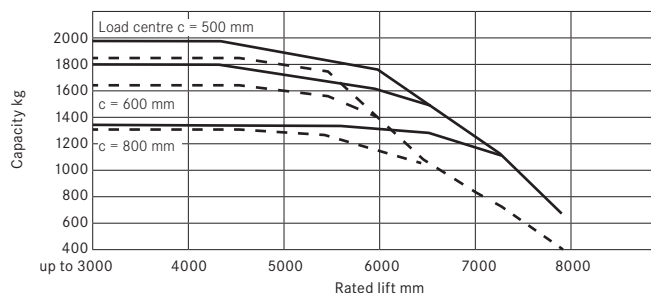

Capacities RX 20-20P Tele-/ HiLo - mast

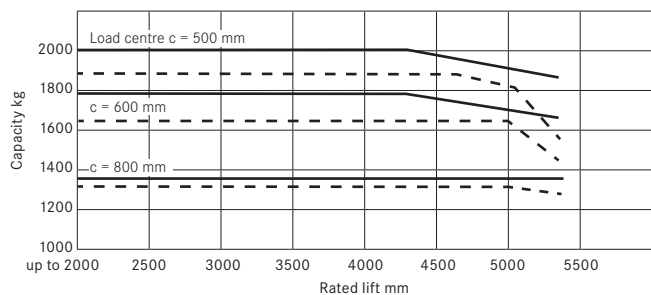

Capacities RX 20-20P Triplex mast

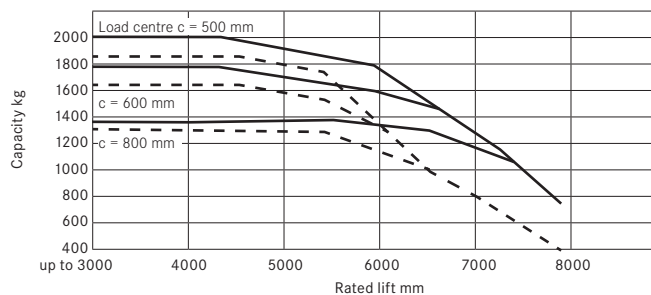

Capacities RX 20-20P/h Tele-/ HiLo - mast

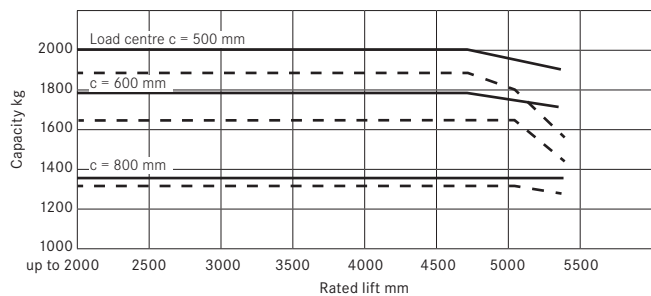

Capacities RX 20-20P/h Triplex mast

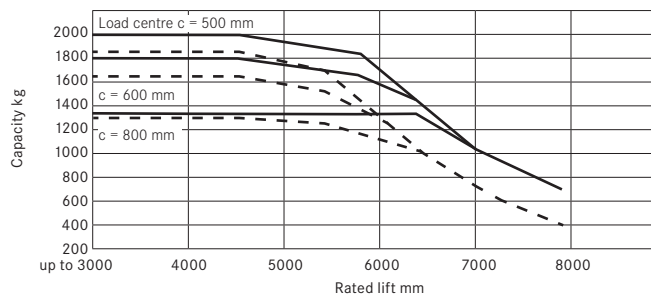

———— Fork carriage    - - - - - Hook-on sideshift

## Drive

Both of the energy efficient three-phase drive units of the RX 20 drive the front wheels and have optimised noise levels. High traction power and driving dynamics, whether on uneven ground or when working on ramps, ensure a high throughput of pallets. One characteristic of the RX 20's drive is the strong development of power from a standstill up to maximum speed. This ensures maximum power is readily available at kerbs or when pushing pallets. The maintenance-free and highly efficient three-phase drive guarantees a long battery operating life. Thanks to complete enclosure the whole drive is protected against the ingress of damaging dust and water spray, so that even applications in the worst conditions are no problem.

Thanks to regenerative braking the motors feed back up to 15% of the energy back into the battery when the drive pedal is released. This dramatically increases the useful time from a single battery charge by up to 1.5 hours. This means that interim battery charging, or even battery changing, is often unnecessary.

The STILL controller ensures optimum energy use and enables the truck to be held on gradients without the need to use the foot brake. The power electronics are protected within the counterweight, which acts as a heat sync. The heat from the controller is thus dissipated into the counterweight over a large area. This arrangement provides very good cooling without the need for additional fans or filters, making the truck more reliable and quieter in use.

## Blue-Q energy optimisation

- Activation of the Blue-Q efficiency mode at the push of a button.
- Saves energy without impairing throughput by intelligently optimising the truck's drive characteristics.
- Intelligently switches off electrical consumers.
- A saving in energy consumption of up to 20%, depending on the application and the truck's equipment.

## Electrical system

The electrical system on the RX 20 works digitally. The two separate CAN bus systems allow operation without repercussions on the drive train. This provides breakdown security. At the same time the robust controller with its two processors provides mutual monitoring for the greatest possible safety. Simple retro-fitting of other electrical units is possible through pre-prepared connections.

The RX 20 supports all functions of FleetManager 4.x: All information about the vehicle, such as the operating hours, deployment times and energy consumption, can be depicted transparently by way of the innovative online tool – anytime and anywhere. Control of the vehicle access entitlement by PIN, chip or an employee card also ensures maximum security when in operation.

## Mast

Depending on the application, the telescopic, HiLo or triplex options offer the following:

- Telescopic: an inexpensive mast design suitable for many applications, with full visibility through the mast.
- HiLo: supplements the telescopic mast with an additional central full free lift cylinder to allow high stacking under low ceilings, e. g. for container or lorry use, right up to the roof.
- Triplex: for use where there are low doorways but high lift heights, for utilisation of warehouses right up to the roof.

## Hydraulic system

The speed of the pump motor is demand controlled and precise. It operates only when either the valve levers or steering wheel are moved, thus providing longer usage from a battery charge. The

sensitive operation of the hydraulics increases working safety by positioning loads to the nearest millimetre. The hydraulics improve the energy consumption thanks to:

- The high efficiency of the noise reduced hydraulic pump.
- The replacement of the pressure make-up valves with load holding valves.

The priority valve for the steering is directly connected to the pump so that hydraulic interfaces and hoses are done away with. This ensures safer, cleaner operation.

## Driver's compartment

The driver's work place in the RX 20:

- The large footwell with its inclined floor plate and anti-slip covering provides quick, convenient entry and exit and also a relaxed leg position when driving.
- The adjustable steering column with its small steering wheel provides an ergonomic match to the driver and reduces steering movements.
- The automotive style foot pedal arrangement can optionally be replaced by a dual pedal arrangement.
- The drive direction switch on the valve lever (hoist and lower) aids untiring concentrated work, even during long shifts, because it allows convenient changing of the drive direction without changing grip.
- Thanks to the heated, fully graphic display, the time, maintenance intervals and battery state are clearly displayed, even when changing from cold to warm areas of use. The whole RX 20 is subjected to constant on-board diagnosis.
- With 5 selectable drive programs the driver can match the driving characteristics of the RX 20 to the application or to what is personally preferred at any time. Each program can be precisely adapted to the application profile in order to achieve optimum economy and load turnround performance.
- The driver's compartment of the RX 20 provides enough head room even for tall drivers, as well as good all round vision thanks to the large viewing panels in the roof, very slim overhead guard legs and the high seating position.

## Safety

Electrical braking when the drive pedal is released, fully automatic hold-on-ramp feature which works without using the brakes, plus the mechanical parking and service brake guarantees safe use at any time. Battery changes on the RX 20 are carried out using a hand pallet truck, low lift pallet truck, forklift truck or hoist. Along with the considerable saving in time compared with conventional craning of the battery, especially with cab variants, this concept minimizes the risk of crushing and damage of any sort that could occur with a heavy swinging battery.

## Service

The maintenance interval of the RX 20 is 1000 hours or 12 months. These intervals save time and maintenance costs – especially in single-shift operation, where 1000 hours roughly corresponds to the number of annual operating hours, thus the maintenance and annual examination can be carried out at the same time.

Quick diagnosis by laptop computer and good accessibility of all maintenance components in conjunction with the availability of all necessary parts guarantee short service times and a high level of availability for the RX 20.

# STILL



STILL Materials Handling Ltd

Aston Way

Leyland Preston

PR26 7UX

Tel.: +44 (0)845 603 6827

Fax: +44 (0)1772 454668

info@still.co.uk

**For further information please visit:**

**www.still.co.uk**

STILL Materials Handling Ltd

19 Hennock Road

Marsh Barton Trading Estate

Exeter

EX2 8RU

Tel.: +44 (0)1392 435151

Fax: +44 (0)1392 824328

STILL Materials Handling Ltd

George Henry Road

Graet Bridge

West Midlands

DY4 7BZ

Tel.: +44 (0)845 603 6827

Fax: +44 (0)121 520 9945

STILL is certified in the following areas: Quality management, occupational safety, environmental protection and energy management.



first in intralogistics