

KOBELCO

Performance  Design

SK350_{LC} SK350_{NLC}

- Bucket capacity:
1.20–1.80 m³
- Engine power:
213 kW / 2,100 min⁻¹
- Operating weight:
36,600–39,300 kg



Complies with the EU Stage V
exhaust emission regulation

We Save You Fuel
Achieving a Low-Carbon Society



Performance Design

SK350LC/SK350NLC of KOBELCO has realised a completely new value by harmonising PERFORMANCE – greater efficiency and productivity with speed and DESIGN – operator-based operability and comfort, refusing to accept any compromises. In pursuit of unique and matchless machines which are unforgettable once you use them, KOBELCO will continue to rise to meet every challenge.



THE ULTIMATE IN SIMPLE AND ELEGANT DESIGN

Our pursuit of functional beauty and aesthetic sense produced a new interior design.

Jog dial

This jog dial integrates multiple functions to realise simple operations. Even with gloved hands, the operator can set various machine conditions without stress.

LED backlights

The switches and dials have LED backlights – they provide a bright, clear view in the dark and set a luxurious mood.







UNFORGETTABLE COMFORT

1 Air suspension seat with heating

A GRAMMER* seat is installed as standard equipment, which achieves excellent shock absorption and superior ride comfort.

*GRAMMER is trademark of GRAMMER AG, registered in Germany and other countries.

2 Air-conditioner

Air is blown against the operator's waist and the back of their head, offering more comfortable operation.

3 Lever angles allow for comfortable operations

The operator can move the levers horizontally without twisting their wrist, which reduces the fatigue caused by the operations.



New Hydraulic Control

Our newly upgraded hydraulic control system responds to shorter lever strokes than current models, delivering swifter, more precise movement and improved lever operability.

4 LED door light

The LED interior light automatically turns on when the door is opened or when the ignition is set to OFF. This ensures easy entry and exit at nighttime.

5 Parallel wipers secure a wide field of view



KOBELCO

ECO

04:33



SETTING MENU



PICTURE OF CAMERA



CLOCK SETTING



SCREEN BRIGHTNESS



MAINTENANCE



CONSUMPTION



LANGUAGE SELECTION



PRESSURE RELEASE



A WIDER VIEW BRINGS A WIDER RANGE OF USE

10-inch colour monitor (the largest in the industry)

The easy-to-operate menu screen facilitates reading of important information. Images from the built-in cameras can be checked on the large screen, which helps secure safety. In addition, each icon has become easy to recognise. A password is required when starting the engine for greater security.



The right camera and rear view camera (right side view mode)



The right camera and rear view camera (straight view mode)



The bird's-eye view



The eagle eye view

Right camera and rear view camera

Images from the right camera and rear view camera are displayed together on the large colour monitor. The right camera view can be selected between the straight view mode and right side view mode.

In addition, the bird's-eye view mode and the eagle eye mode can also be selected.

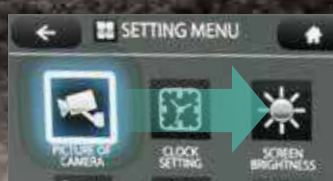

Screen display linked with the jog dial operation

The jog dial can be operated as desired without causing stress. Turn the jog dial to the right or left to select an item and press the dial to confirm the selection.



Independent Travel

Selecting Independent Travel dedicates one hydraulic pump to travel and one to the attachment on a continuous basis, allowing for a smooth and constant movement speed even while swinging or using the boom or attachment. With Independent Travel, safely carrying a large pipe across a job site is a breeze.

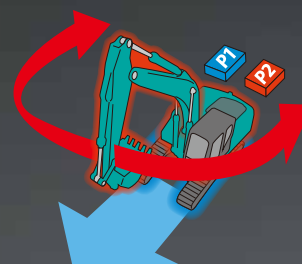

EXPERIENCING A COMPETENT PERFORMANCE

Excellent machine stability, plus an EU Stage compliant engine

Equipped with the new STAGE V engine, the SK350LC/SK350NLC feature outstanding stability thanks to an innovative new shape for conventional excavator.



Model: HINO J08EYD-KSSA

Engine output

213 kW / 2,100 min⁻¹

Max. bucket digging force (Arm: 3.30 m)

Normal: **222** kN

With Power Boost: **244** kN

Lifting capacity

18,060 kg

(Reach: 4.50 m Boom: 6.50 m Arm: 3.30 m Bucket: without Shoe: 600 mm <Heavy Lift>



GREATER MULTI-FUNCTION CAPABILITIES

Attachment mode

The flow-rate and working pressure modes of the bucket, breaker, nibbler, and rotating grapple are set before delivery, which allows you to start operating immediately. Mode settings for other attachments, such as the tilt rotator, can easily be added or changed.

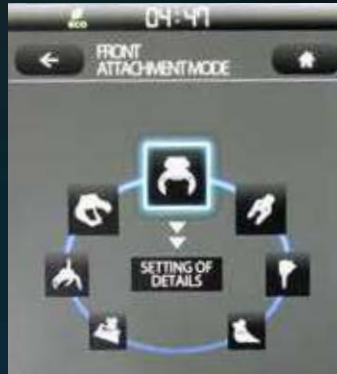

Adjustment for hydraulic flow

Divide ratio of hydraulic flow can be adjusted by service factory for custom usage.



EASY MAINTENANCE



Standard OPG Level II top guard

The standard OPG Level II top guard can be tilted open for easy window cleaning. Meets standard FOPS and OPG Level II top guard requirements. (ISO 10262:1998)



Two-stage air filter



Urea tank

Urea filter cap is placed on the step for easy access.



Left side (radiator and cooling system elements)

Laid out for easy access to radiator and cooling system.



Right side



Fuel filter/Pre-filter



Engine oil filter

DURABILITY YOU CAN TRUST

Enhanced body rigidity for 35-ton class machines

The SK350LC/SK350NLC machines are widely used in mid-scale construction projects and harsh worksites. The components have been reviewed and improvements have been made to their durability to ensure stable performance in such environments.

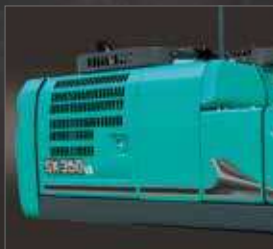

Panels and supports

The right and left side panels and rear supports have been thicker to enhance body rigidity.



Bucket cylinder rod pin

The increased diameter of the bucket cylinder rod pin contributes to enhanced durability for various types of attachments.

CONVENIENT AND SENSIBLE EQUIPMENT



Engine start password

A password is required when starting the engine for greater security. The initial password must be set at our workshop.



Wiper adjustment function

In addition to the intermittent wiper mode and continuous wiper mode, the one-time wiper mode was added.



Parallel wiper/Sun screen



Console mount

The console-integrated seat allows for comfortable operation.



DAB + radio (FM/AM & AUX & USB & Bluetooth® & hands-free telephone)



USB port / 12 V power supply



Smartphone holder

You can use the holder with your smartphone connected to the USB port.



KOBELCO MONITORING EXCAVATOR SYSTEM



Customer



KOBELCO office



KOBELCO service personnel



Remote Monitoring for Peace of Mind

KOMEXS (Kobelco Monitoring Excavator System) uses satellite communication and internet to relay data, and therefore can be deployed in areas where other forms of communication are difficult. When a hydraulic excavator is fitted with this system, data on the machine's operation, such as operating hours, location, fuel consumption, and maintenance status can be obtained remotely.

Direct Access to Operational Status

Location Data

Accurate location data can be obtained even from sites where communications are difficult.



Latest location

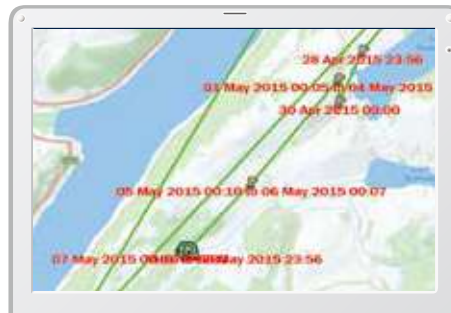

Location records

Period	11 Apr, 2015	11	10 May, 2015	Search
Type of Operation	Working Hrs		Ratio	
Total Working Hrs	169 Hrs		100 %	
Digging Hrs	72.2 Hrs		43 %	
Traveling Hrs	18.3 Hrs		11 %	
Idle Hrs	25.9 Hrs		9 %	
Opt. Att. Hrs	62.5 Hrs		37 %	
Crane Mode Hrs	0 Hrs		0 %	

Work data

Operating Hours

- A comparison of operating times of machines at multiple locations shows which locations are busier and more profitable.
- Operating hours on site can be accurately recorded, for running time calculations needed for rental machines, etc.

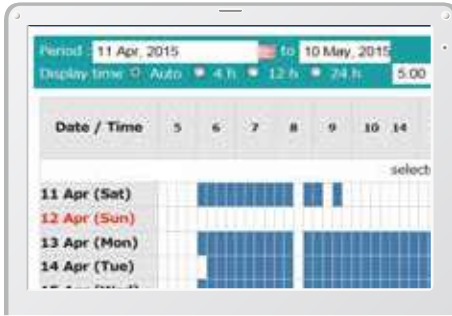

Daily report

Fuel Consumption Data

Data on fuel consumption and idling times can be used to indicate improvements in fuel consumption.

Work mode	Working Hrs	Total Fuel Consumption
H mode	2:06	24.5 L
S mode	0:00	0.0 L
E mode	169:19	1489.7 L
TOTAL	171:25	1514.2 L

Fuel consumption

Graph of Work Content

The graph shows how working hours are divided among different operating categories, including digging, idling, travelling and optional operations.



Work status

Maintenance Data and Warning Alerts

Machine Maintenance Data

- Provides maintenance status of separate machines operating at multiple sites.
- Maintenance data is also relayed to KOBELCO service personnel, for more efficient planning of periodic servicing.

Model	Serial No.	Hour Meter	Engine Oil
SK135RLC-3/SK140SRL	YH07-09221	734 Hr	434
SK135RLC-3/SK140SRL	YH07-09289	73 Hr	429
SK210LC-9	YQ13-10454	960 Hr	58
SK210LC-9	YQ13-10461	549 Hr	498
SK75SR-	YT08-20374		

Maintenance

Warning Alerts

This system warns an alert if an anomaly is sensed, preventing damage that could result in machine downtime.

Alarm Information Can Be Received through E-mail

Alarm information or maintenance notice can be received through E-mail, using a computer or cell phone.



Alarm messages can be received on mobile device.

Daily/Monthly Reports

Operational data downloaded onto a computer helps in formulating daily and monthly reports.

Security System

Engine Start Alarm

The system can be set an alarm if the machine is operated outside designated time.

Engine start alarm outside prescribed work time

Area Alarm

It can be set an alarm if the machine is moved out of its designated area to another location.

Alarm for outside of reset area

Specifications



Engine

Model	HINO J08EYD-KSSA
Type	Direct injection, water-cooled, 4-cycle diesel engine with turbocharger, intercooler complies with EU Stage V exhaust emission regulation
No. of cylinders	6
Bore and stroke	112 mm x 130 mm
Displacement	7.684 L
Rated power output	201 kW/2,100 min ⁻¹ (ISO 9249)
	213 kW/2,100 min ⁻¹ (ISO 14396)
Max. torque	988 N·m/1,600 min ⁻¹ (ISO 9249)
	1,017 N·m/1,600 min ⁻¹ (ISO 14396)



Hydraulic System

Pump	
Type	Axial piston pumps + extra gear pump + pilot gear pump
Max. discharge flow	2 x 294 L/min, 1 x 42.6 L/min, 1 x 21 L/min
Relief valve setting	
Boom, arm and bucket	34.3 MPa {350 kgf/cm ² }
Power Boost	37.8 MPa {385 kgf/cm ² }
Travel circuit	35.8 MPa {365 kgf/cm ² }
Swing circuit	29.5 MPa {300 kgf/cm ² }
Control circuit	5.0 MPa {50 kgf/cm ² }
Pilot control pump	Gear type
Main control valve	8-spool
Oil cooler	Air cooled type



Swing System

Swing motor	One fixed displacement piston motor
Brake	Hydraulic; locking automatically when the swing control lever is in neutral position
Parking brake	Oil disc brake, hydraulic operated automatically
Swing speed	10.0 min ⁻¹
Tail swing radius	3,600 mm
Min. front swing radius	4,310 mm
Swing torque	119.6 kN·m



Attachments

Backhoe bucket and combination

Use	Backhoe bucket					
			Normal digging		Light-duty	
Bucket capacity	ISO heaped	m ³	1.20	1.40	1.60	1.80
Opening width	With side cutter	mm	1,240	1,420	1,570	–
	Without side cutter	mm	1,110	1,300	1,450	1,680
No. of teeth			4	5	5	5
Bucket weight		kg	930	1,070	1,140	1,200
Combination	2.60 m short arm		○	○	◎	△
	3.30 m standard arm		○	◎	△	×
	4.15 m long arm		◎	△	×	×

◎ Standard ○ Recommended △ Loading only × Not recommended



Travel System

Travel motors	2 x axial-piston, two-step motors
Travel brakes	Hydraulic brake per motor
Parking brakes	Oil disc brake per motor
Travel shoes	48 each side
Travel speed	5.6/3.3 km/h
Drawbar pulling force	321 kN (ISO 7464)
Gradeability	70 % {35°}



Cab & Control

Cab	
All-weather, sound-suppressed steel cab mounted on the high suspension mounts filled with silicone oil and equipped with a heavy, insulated floor mat.	
Control	
Two hand levers and two foot pedals for travel	
Two hand levers for excavating and swing	
Electric rotary-type engine throttle	
Noise levels	
External	105 dB(A) (2000/14/EC)
Operator	72 dB(A) (ISO 6396)
Vibration levels	
Hand/arm*	≤ 2.5 m/s ²
Body*	≤ 0.5 m/s ²

*For the risk assessment according to 2002/44/EC, refer to ISO/TR 25398: 2006.



Boom, Arm & Bucket

Boom cylinders	140 mm x 1,550 mm
Arm cylinder	170 mm x 1,788 mm
Bucket cylinder	150 mm x 1,193 mm



Refilling Capacities & Lubrications

Fuel tank	503 L
Cooling system	35 L
Engine oil	28.5 L
Travel reduction gear	2 x 8.0 L
Swing reduction gear	1 x 7.4 L
Hydraulic oil tank	245 L tank oil level
	410 L hydraulic system
DEF/Urea tank	83 L



Working Ranges

Unit: m

Range	Arm	6.50 m		
		Short 2.60 m	Standard 3.30 m	Long 4.15 m
a- Max. digging reach		10.61	11.26	11.97
b- Max. digging reach at ground level		10.40	11.06	11.79
c- Max. digging depth		6.86	7.56	8.41
d- Max. digging height		10.26	10.58	10.70
e- Max. dumping clearance		7.06	7.37	7.53
f- Min. dumping clearance		3.32	2.62	1.76
g- Max. vertical wall digging depth		5.84	6.61	7.27
h- Min. swing radius		4.46	4.31	4.43
i- Horizontal digging stroke at ground level		4.21	5.82	7.21
j- Digging depth for 2.4 m (8') flat bottom		6.67	7.40	8.27
Bucket capacity ISO heaped m ³		1.60	1.40	1.20

Digging Force (ISO 6015)

Unit: kN

Arm length	Short 2.60 m	Standard 3.30 m	Long 4.15 m
Bucket digging force	221 243*	222 244*	220 242*
Arm crowding force	205 225*	163 180*	140 154*

*Power Boost engaged.

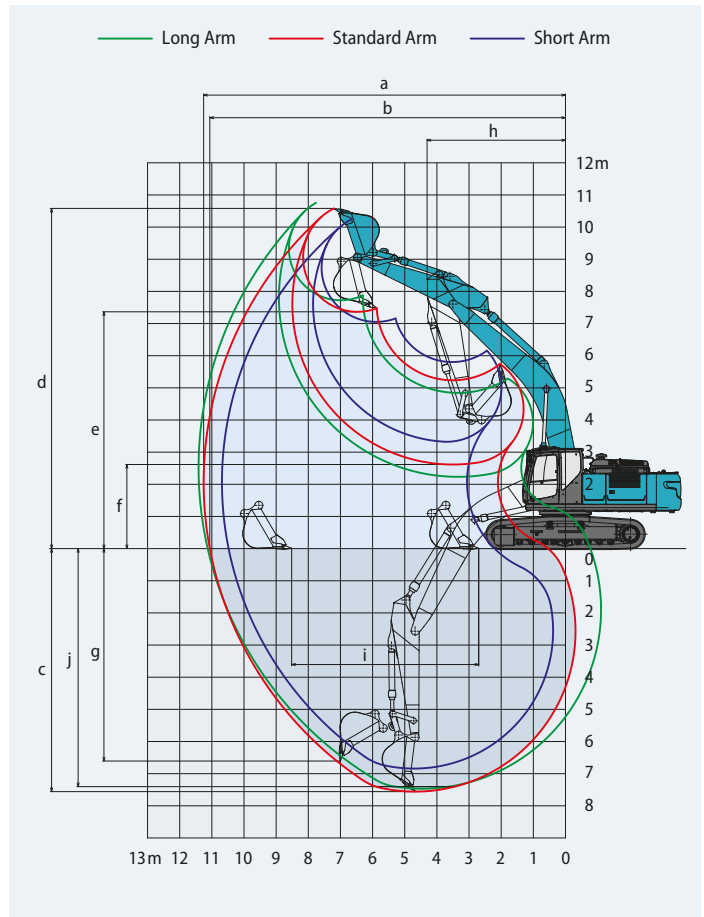

Dimensions

Arm length		Short 2.60 m	Standard 3.30 m	Long 4.15 m
A Overall length		11,380	11,300	11,330
B Overall height (to top of boom)		3,690	3,420	3,590
C Overall width of crawler	SK350LC		3,190	
	SK350NLC		2,990	
D Overall height (to top of cab)			3,200	
E Ground clearance of rear end*			1,190	
F Ground clearance*			485	
G Tail swing radius			3,600	

Unit: mm

G'	Distance from centre of swing to rear end	3,600
H	Tumbler distance	4,050
I	Overall length of crawler	4,960
J Track gauge	SK350LC	2,590
	SK350NLC	2,390
K	Shoe width	600
L	Overall width of upperstructure	2,980

*Without including height of shoe

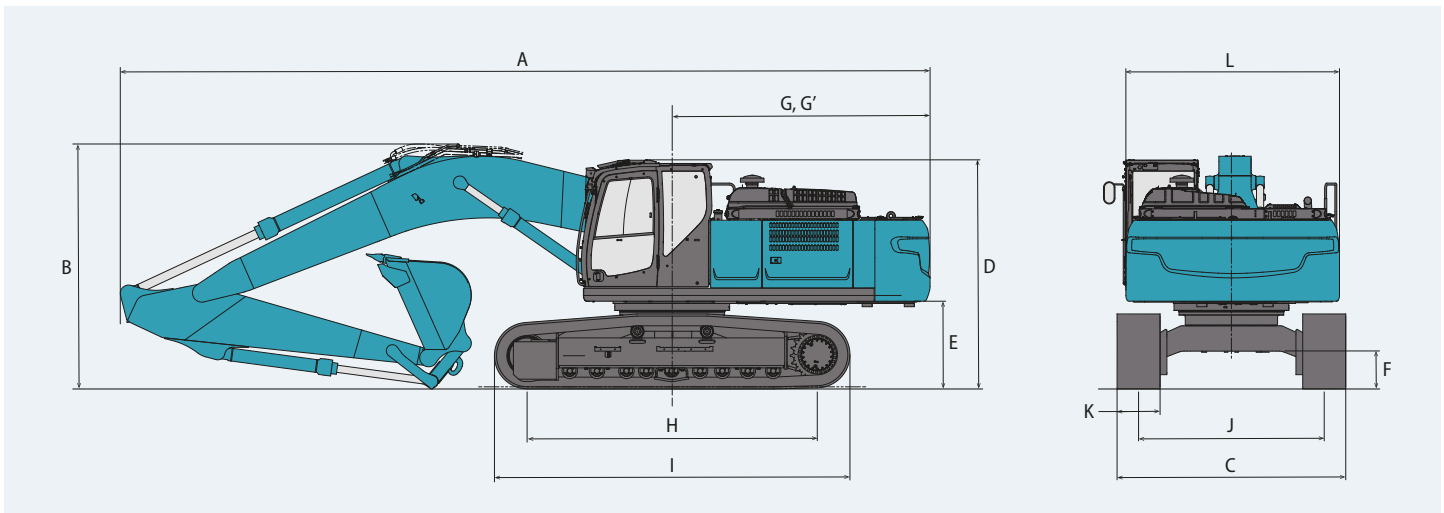

Operating weight & ground pressure

In standard trim, with standard boom, 3.30 m arm, and 1.40 m³ ISO heaped bucket

Shaped			Triple grouser shoes (even height)			
Shoe width	mm		600	700	800	900
Overall width of crawler	SK350LC	mm	3,190	3,290	3,390	3,490
	SK350NLC	mm	2,990	3,090	—	—
Ground pressure	SK350LC	kPa	69	60	53	48
	SK350NLC	kPa	69	60	—	—
Operating weight	SK350LC	kg	36,700	37,600	38,000	38,400
	SK350NLC	kg	36,600	37,500	—	—

Lift Capacities

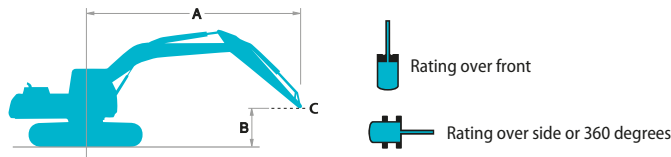

A: Reach from swing centreline to arm top
 B: Arm top height above/below ground
 C: Lift point
 Bucket: Without bucket
 Relief valve setting: 37.8 MPa (385 kgf/cm²)

SK350LC		Boom: 6.50 m Arm: 3.30 m Bucket: without Shoe: 600 mm (Heavy Lift)														
B	A	1.5 m		3.0 m		4.5 m		6.0 m		7.5 m		9.0 m		At max. reach		Radius
		Rating over front	Rating over side or 360 degrees	Rating over front	Rating over side or 360 degrees	Rating over front	Rating over side or 360 degrees	Rating over front	Rating over side or 360 degrees	Rating over front	Rating over side or 360 degrees	Rating over front	Rating over side or 360 degrees	Rating over front	Rating over side or 360 degrees	
9.0 m	kg													*6,370	*6,370	6.56 m
7.5 m	kg									*7,810	*7,810			*5,840	*5,840	7.86 m
6.0 m	kg									*7,930	*7,930			*5,640	*5,640	8.71 m
4.5 m	kg							*9,720	*9,720	*8,490	7,700	*7,850	5,750	*5,650	5,480	9.25 m
3.0 m	kg					*15,090	*15,090	*11,160	10,160	*9,230	7,360	*8,160	5,600	*5,830	5,110	9.52 m
1.5 m	kg					*17,300	14,250	*12,430	9,580	*9,940	7,040	8,400	5,430	*6,200	4,980	9.54 m
G.L.	kg					*18,060	13,770	*13,170	9,200	*10,400	6,810	8,270	5,320	*6,830	5,070	9.33 m
-1.5 m	kg			*15,390	*15,390	*17,700	13,670	*13,230	9,040	*10,420	6,700			*7,890	5,410	8.85 m
-3.0 m	kg	*17,520	*17,520	*22,280	*22,280	*16,380	13,810	*12,490	9,080	*9,690	6,750			*8,640	6,160	8.07 m
-4.5 m	kg			*18,200	*18,200	*13,800	*13,800	*10,490	9,330					*8,540	7,810	6.88 m

SK350LC		Boom: 6.50 m Arm: 4.15 m Bucket: without Shoe: 600 mm (Heavy Lift)														
B	A	1.5 m		3.0 m		4.5 m		6.0 m		7.5 m		9.0 m		At max. reach		Radius
		Rating over front	Rating over side or 360 degrees	Rating over front	Rating over side or 360 degrees	Rating over front	Rating over side or 360 degrees	Rating over front	Rating over side or 360 degrees	Rating over front	Rating over side or 360 degrees	Rating over front	Rating over side or 360 degrees	Rating over front	Rating over side or 360 degrees	
9.0 m	kg									*5,080	*5,080			*4,770	*4,770	7.56 m
7.5 m	kg													*4,460	*4,460	8.71 m
6.0 m	kg									*6,890	*6,890	*6,580	5,910	*4,350	*4,350	9.49 m
4.5 m	kg									*7,520	*7,520	*6,990	5,760	*4,380	*4,380	9.98 m
3.0 m	kg			*21,160	*21,160	*13,040	*13,040	*9,950	*9,950	*8,350	7,380	*7,420	5,550	*4,530	4,480	10.23 m
1.5 m	kg					*15,760	14,500	*11,410	9,620	*9,190	6,990	*7,880	5,330	*4,820	4,350	10.25 m
G.L.	kg			*10,820	*10,820	*17,290	13,670	*12,470	9,100	*9,850	6,670	8,120	5,150	*5,280	4,390	10.05 m
-1.5 m	kg	*10,180	*10,180	*14,950	*14,950	*17,630	13,340	*12,920	8,810	*10,150	6,480	8,010	5,050	*6,040	4,620	9.62 m
-3.0 m	kg	*14,870	*14,870	*20,400	*20,400	*16,950	13,330	*12,670	8,740	*9,910	6,430			*7,340	5,150	8.91 m
-4.5 m	kg	*20,310	*20,310	*21,170	*21,170	*15,190	13,570	*11,490	8,870	*8,720	6,570			*8,060	6,210	7.85 m
-6.0 m	kg			*15,790	*15,790	*11,710	*11,710	*8,510	*8,510					*7,910	*7,910	6.26 m

SK350LC		Boom: 6.50 m Arm: 2.60 m Bucket: without Shoe: 600 mm (Heavy Lift)										
B	A	3.0 m		4.5 m		6.0 m		7.5 m		At max. reach		Radius
		Rating over front	Rating over side or 360 degrees	Rating over front	Rating over side or 360 degrees	Rating over front	Rating over side or 360 degrees	Rating over front	Rating over side or 360 degrees	Rating over front	Rating over side or 360 degrees	
7.5 m	kg									*8,760	8,640	7.06 m
6.0 m	kg					*9,360	*9,360	*8,610	7,750	*8,540	6,930	8.00 m
4.5 m	kg			*13,460	*13,460	*10,470	*10,470	*9,030	7,510	*8,510	6,060	8.58 m
3.0 m	kg					*11,770	9,860	*9,650	7,200	*8,600	5,610	8.87 m
1.5 m	kg					*12,800	9,350	*10,200	6,920	8,480	5,460	8.89 m
G.L.	kg			*17,830	13,610	*13,230	9,070	*10,460	6,740	8,720	5,590	8.66 m
-1.5 m	kg			*16,930	13,660	*12,940	9,000	*10,170	6,700	*9,090	6,050	8.15 m
-3.0 m	kg	*19,180	*19,180	*15,120	13,900	*11,730	9,140			*9,110	7,120	7.29 m
-4.5 m	kg	*14,570	*14,570	*11,740	*11,740					*8,590	*8,590	5.95 m

SK350NLC		Boom: 6.50 m Arm: 3.30 m Bucket: without Shoe: 600 mm (Heavy Lift)															
B \ A		1.5 m		3.0 m		4.5 m		6.0 m		7.5 m		9.0 m		At max. reach		Radius	
9.0 m	kg														*6,370	*6,370	6.56 m
7.5 m	kg									*7,810	7,500				*5,840	*5,840	7.86 m
6.0 m	kg									*7,930	7,400				*5,640	*5,640	8.71 m
4.5 m	kg							*9,720	*9,720	*8,490	7,140	*7,850	5,320		*5,650	5,070	9.25 m
3.0 m	kg					*15,090	14,020	*11,160	9,360	*9,230	6,800	*8,160	5,170		*5,830	4,720	9.52 m
1.5 m	kg					*17,300	12,960	*12,430	8,800	*9,940	6,490	8,370	5,010		*6,200	4,590	9.54 m
G.L.	kg					*18,060	12,500	*13,170	8,430	*10,400	6,260	8,240	4,890		*6,830	4,660	9.33 m
-1.5 m	kg			*15,390	*15,390	*17,700	12,400	*13,230	8,270	*10,420	6,150				*7,890	4,980	8.85 m
-3.0 m	kg	*17,520	*17,520	*22,280	*22,280	*16,380	12,530	*12,490	8,310	*9,690	6,200				*8,640	5,670	8.07 m
-4.5 m	kg			*18,200	*18,200	*13,800	12,880	*10,490	8,560						*8,540	7,190	6.88 m

SK350NLC		Boom: 6.50 m Arm: 4.15 m Bucket: without Shoe: 600 mm (Heavy Lift)															
B \ A		1.5 m		3.0 m		4.5 m		6.0 m		7.5 m		9.0 m		At max. reach		Radius	
9.0 m	kg									*5,080	*5,080				*4,770	*4,770	7.56 m
7.5 m	kg														*4,460	*4,460	8.71 m
6.0 m	kg									*6,890	*6,890	*6,580	5,470		*4,350	*4,350	9.49 m
4.5 m	kg									*7,520	7,210	*6,990	5,330		*4,380	*4,380	9.98 m
3.0 m	kg			*21,160	*21,160	*13,040	*13,040	*9,950	9,520	*8,350	6,820	*7,420	5,120		*4,530	4,120	10.23 m
1.5 m	kg					*15,760	13,190	*11,410	8,830	*9,190	6,430	*7,880	4,900		*4,820	3,990	10.25 m
G.L.	kg			*10,820	*10,820	*17,290	12,390	*12,470	8,320	*9,850	6,120	8,100	4,730		*5,280	4,020	10.05 m
-1.5 m	kg	*10,180	*10,180	*14,950	*14,950	*17,630	12,070	*12,920	8,040	*10,150	5,930	7,990	4,630		*6,040	4,230	9.62 m
-3.0 m	kg	*14,870	*14,870	*20,400	*20,400	*16,950	12,060	*12,670	7,970	*9,910	5,890				*7,340	4,720	8.91 m
-4.5 m	kg	*20,310	*20,310	*21,170	*21,170	*15,190	12,290	*11,490	8,100	*8,720	6,020				*8,060	5,700	7.85 m
-6.0 m	kg			*15,790	*15,790	*11,710	*11,710	*8,510	*8,510						*7,910	*7,910	6.26 m

SK350NLC		Boom: 6.50 m Arm: 2.60 m Bucket: without Shoe: 600 mm (Heavy Lift)											
B \ A		3.0 m		4.5 m		6.0 m		7.5 m		At max. reach		Radius	
7.5 m	kg										*8,760	8,010	7.06 m
6.0 m	kg					*9,360	*9,360	*8,610	7,190		*8,540	6,420	8.00 m
4.5 m	kg			*13,460	*13,460	*10,470	9,700	*9,030	6,950		*8,510	5,600	8.58 m
3.0 m	kg					*11,770	9,070	*9,650	6,640		*8,600	5,180	8.87 m
1.5 m	kg					*12,800	8,570	*10,200	6,360		8,450	5,030	8.89 m
G.L.	kg			*17,830	12,340	*13,230	8,290	*10,460	6,190		8,690	5,140	8.66 m
-1.5 m	kg			*16,930	12,390	*12,940	8,230	*10,170	6,160		*9,090	5,570	8.15 m
-3.0 m	kg	*19,180	*19,180	*15,120	12,620	*11,730	8,370				*9,110	6,540	7.29 m
-4.5 m	kg	*14,570	*14,570	*11,740	*11,740						*8,590	*8,590	5.95 m

Notes:

1. Do not attempt to lift or hold any load that is greater than these lift capacities at their specified lift point radius and heights. Weight of all accessories must be deducted from the above lift capacities.
2. Lift capacities are based on machine standing on level, firm, and uniform ground. User must make allowance for job conditions such as soft or uneven ground, out of level conditions, side loads, sudden stopping of loads, hazardous conditions, experience of personnel, etc.
3. Arm top defined as lift point.
4. The above lift capacities are in compliance with ISO 10567. They do not exceed 87% of hydraulic lift

- capacity or 75% of tipping load. Lift capacities marked with an asterisk(*) are limited by hydraulic capacity rather than tipping load.
5. Operator should be fully acquainted with the Operator's and Maintenance Instructions before operating this machine. Rules for safe operation of equipment should be adhered to at all times.
6. Lift capacities apply to only machine as originally manufactured and normally equipped by KOBELCO CONSTRUCTION MACHINERY CO., LTD.

2 Piece Boom Specifications



Engine

Model	HINO J08EYD-KSSA
Type	Direct injection, water-cooled, 4-cycle diesel engine with turbocharger, intercooler complies with EU Stage V exhaust emission regulation
No. of cylinders	6
Bore and stroke	112 mm x 130 mm
Displacement	7.684 L
Rated power output	201 kW/2,100 min ⁻¹ (ISO 9249) 213 kW/2,100 min ⁻¹ (ISO 14396)
Max. torque	988 N·m/1,600 min ⁻¹ (ISO 9249) 1,017 N·m/1,600 min ⁻¹ (ISO 14396)



Hydraulic System

Pump	
Type	Axial piston pumps + extra gear pump + pilot gear pump
Max. discharge flow	2 x 294 L/min, 1 x 42.6 L/min, 1 x 21 L/min
Relief valve setting	
Boom, arm and bucket	34.3 MPa {350 kgf/cm ² }
Power Boost	37.8 MPa {385 kgf/cm ² }
Travel circuit	35.8 MPa {365 kgf/cm ² }
Swing circuit	29.5 MPa {300 kgf/cm ² }
Control circuit	5.0 MPa {50 kgf/cm ² }
Pilot control pump	Gear type
Main control valve	8-spool
Oil cooler	Air cooled type



Swing System

Swing motor	One fixed displacement piston motor
Brake	Hydraulic; locking automatically when the swing control lever is in neutral position
Parking brake	Oil disc brake, hydraulic operated automatically
Swing speed	10.0 min ⁻¹
Tail swing radius	3,600 mm
Min. front swing radius	3,000 mm
Swing torque	119.6 kN·m



Attachments

Backhoe bucket and combination.

Use	Backhoe bucket					
			Normal digging		Light-duty	
Bucket capacity	ISO heaped	m ³	1.20	1.40	1.60	1.80
Opening width	With side cutter	mm	1,240	1,420	1,570	–
	Without side cutter	mm	1,110	1,300	1,450	1,680
No. of teeth			4	5	5	5
Bucket weight		kg	930	1,070	1,140	1,200
Combination	2.60 m short arm		○	○	◎	△
	3.30 m standard arm		○	◎	△	×
	4.15 m long arm		◎	△	×	×

◎ Standard ○ Recommended △ Loading only × Not recommended



Travel System

Travel motors	2 × axial-piston, two-step motors
Travel brakes	Hydraulic brake per motor
Parking brakes	Oil disc brake per motor
Travel shoes	48 each side
Travel speed	5.6/3.3 km/h
Drawbar pulling force	321 kN (ISO 7464)
Gradeability	70 % {35°}



Cab & Control

Cab	
All-weather, sound-suppressed steel cab mounted on the high suspension mounts filled with silicone oil and equipped with a heavy, insulated floor mat.	
Control	
Two hand levers and two foot pedals for travel	
Two hand levers for excavating and swing	
Electric rotary-type engine throttle	
Noise levels	
External	105 dB(A) (2000/14/EC)
Operator	72 dB(A) (ISO 6396)
Vibration levels	
Hand/arm*	≤ 2.5 m/s ²
Body*	≤ 0.5 m/s ²

*For the risk assessment according to 2002/44/EC, refer to ISO/TR 25398: 2006.



Boom, Arm & Bucket

Boom cylinders	140 mm x 1,550 mm
Arm cylinder	170 mm x 1,788 mm
Bucket cylinder	150 mm x 1,193 mm
jib cylinder	170 mm x 1,335 mm



Refilling Capacities & Lubrications

Fuel tank	503 L
Cooling system	35 L
Engine oil	28.5 L
Travel reduction gear	2 x 8.0 L
Swing reduction gear	1 x 7.4 L
Hydraulic oil tank	245 L tank oil level
	410 L hydraulic system
DEF/Urea tank	83 L



Working Ranges

Unit: m

Boom	3.40 m + 3.07 m		
Range	Short 2.60 m	Standard 3.30 m	Long 4.15 m
a- Max. digging reach	10.68	11.35	12.11
b- Max. digging reach at ground level	10.48	11.16	11.93
c- Max. digging depth	6.51	7.20	8.01
d- Max. digging height	12.09	12.65	13.18
e- Max. dumping clearance	8.72	9.28	9.80
f- Min. dumping clearance	0.82	0.12	0.73
g- Max. vertical wall digging depth	3.92	4.46	5.28
h- Min. swing radius	3.31	3.00	3.14
i- Horizontal digging stroke at ground level	6.67	8.03	9.63
j- Digging depth for 2.4 m (8') flat bottom	6.41	7.11	7.92
Bucket capacity ISO heaped m ³	1.60	1.40	1.20

Digging Force (ISO 6015)

Unit: kN

Arm length	Short 2.60 m	Standard 3.30 m	Long 4.15 m
Bucket digging force	221 243*	222 244*	222 242*
Arm crowding force	205 225*	163 180*	140 154*

*Power Boost engaged.

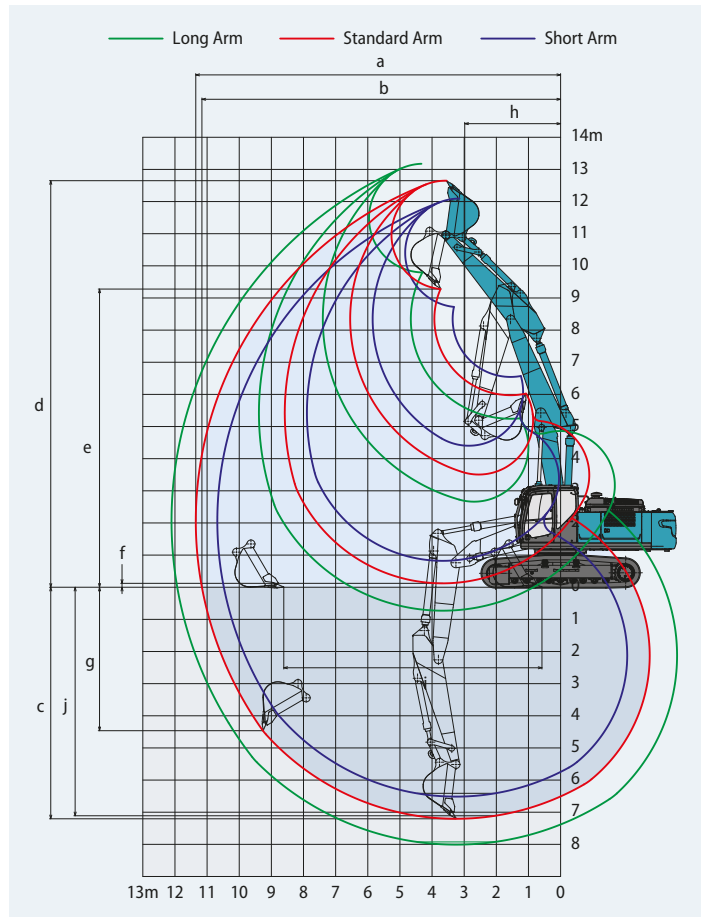

Dimensions

Arm length	Short 2.60 m	Standard 3.30 m	Long 4.15 m
A Overall length	11,290	11,270	11,270
B Overall height (to top of boom)	3,420	3,360	3,670
C Overall width of crawler	SK350LC	3,190	
	SK350NLC	2,990	
D Overall height (to top of cab)	3,210		
E Ground clearance of rear end*	1,190		
F Ground clearance*	485		
G Tail swing radius	3,600		

Unit: mm

G'	Distance from centre of swing to rear end	3,600
H	Tumbler distance	4,050
I	Overall length of crawler	4,960
J Track gauge	SK350LC	2,590
	SK350NLC	2,390
K	Shoe width	600
L	Overall width of upperstructure	2,980

*Without including height of shoe

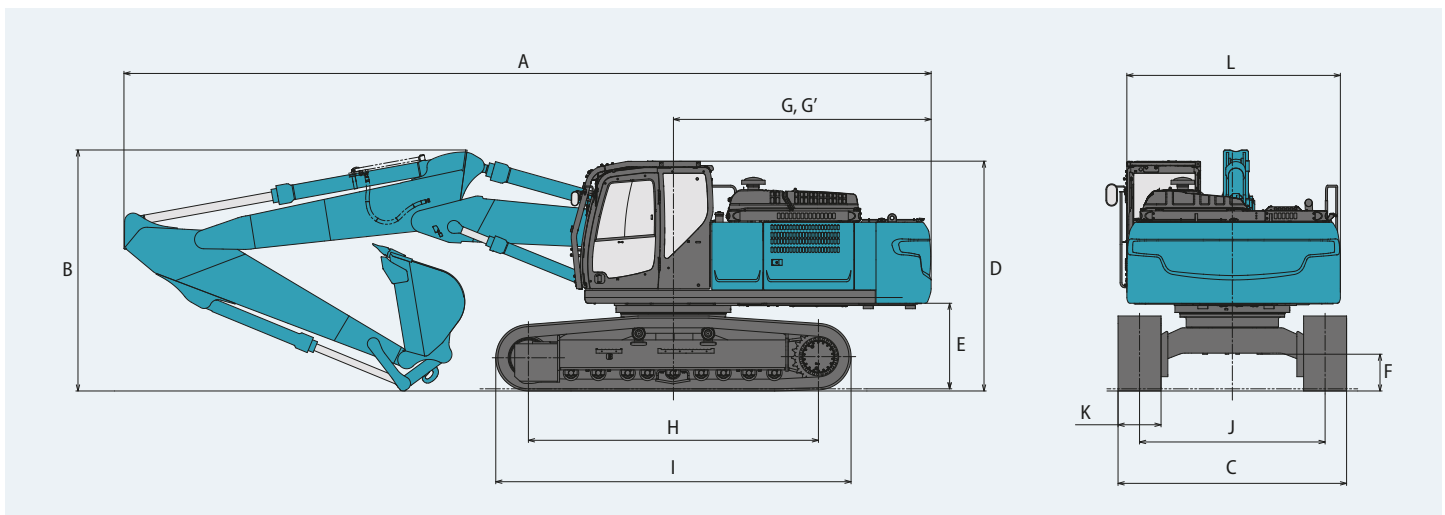

Operating weight & ground pressure

In standard trim, with 2 piece boom, 3.30 m arm, and 1.40 m³ ISO heaped bucket.

Shaped			Triple grouser shoes (even height)			
Shoe width	mm		600	700	800	900
Overall width of crawler	SK350LC	mm	3,190	3,290	3,390	3,490
	SK350NLC	mm	2,990	3,090	—	—
Ground pressure	SK350LC	kPa	76	67	59	53
	SK350NLC	kPa	76	67	—	—
Operating weight	SK350LC	kg	37,700	38,500	38,900	39,300
	SK350NLC	kg	37,600	38,400	—	—

Lift Capacities

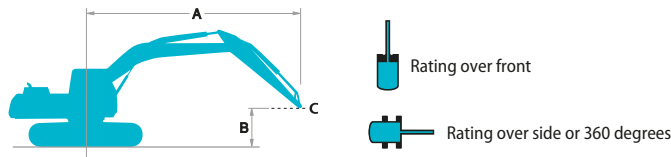

























A: Reach from swing centreline to arm top
 B: Arm top height above/below ground
 C: Lift point
 Bucket: Without bucket
 Relief valve setting: 37.8 MPa (385 kgf/cm²)











SK350LC		2 piece boom		Arm: 3.30 m		Bucket: without		Shoe: 600 mm (Heavy Lift)						
B	A	3.0 m		4.5 m		6.0 m		7.5 m		9.0 m		At max. reach		Radius
10.5 m	kg			*9,280	*9,280							*8,430	*8,430	4.63 m
9.0 m	kg					*7,950	*7,950					*6,880	*6,880	6.70 m
7.5 m	kg					*11,010	*11,010	*6,790	*6,790			*6,000	*6,000	7.98 m
6.0 m	kg			*11,880	*11,880	*11,440	11,290	*5,780	*5,780			*5,700	*5,700	8.82 m
4.5 m	kg			*15,800	*15,800	*12,220	10,710	*5,090	*5,090	*6,010	5,640	*5,610	5,270	9.35 m
3.0 m	kg	*25,710	*25,710	*17,600	15,170	*13,010	10,020	*4,970	*4,970	*6,110	5,500	*5,690	4,940	9.61 m
1.5 m	kg	*27,810	27,660	*18,080	14,060	*13,350	9,430	*5,520	*5,520	*6,410	5,340	*5,950	4,830	9.64 m
G.L.	kg	*22,850	*22,850	*16,900	13,610	*12,910	9,070	*6,850	6,710	*6,790	5,240	*6,410	4,940	9.43 m
-1.5 m	kg	*13,570	*13,570	*14,510	13,560	*11,540	8,950	*8,730	6,620			*6,210	5,300	8.96 m
-3.0 m	kg			*11,000	*11,000	*9,050	9,030	*6,670	*6,670			*4,980	*4,980	8.19 m

SK350LC		2 piece boom		Arm: 4.15 m		Bucket: without		Shoe: 600 mm (Heavy Lift)						
B	A	3.0 m		4.5 m		6.0 m		7.5 m		9.0 m		At max. reach		Radius
10.5 m	kg					*6,110	*6,110					*5,800	*5,800	6.06 m
9.0 m	kg					*8,460	*8,460	*6,160	*6,160			*4,930	*4,930	7.75 m
7.5 m	kg					*8,600	*8,600	*5,270	*5,270			*4,530	*4,530	8.88 m
6.0 m	kg					*9,190	*9,190	*9,070	7,990	*5,200	*5,200	*4,360	*4,360	9.64 m
4.5 m	kg			*11,810	*11,810	*11,270	10,960	*9,470	7,670	*4,880	*4,880	*4,320	*4,320	10.13 m
3.0 m	kg	*24,380	*24,380	*16,330	15,760	*12,240	10,190	*9,920	7,260	*4,820	*4,820	*4,400	4,270	10.37 m
1.5 m	kg	*27,360	*27,360	*17,650	14,310	*12,910	9,470	*3,820	*3,820	*5,140	*5,140	*4,600	4,170	10.39 m
G.L.	kg	*9,090	*9,090	*17,460	13,490	*12,930	8,960	*4,950	*4,950	*5,820	5,060	*4,950	4,230	10.20 m
-1.5 m	kg	*13,370	*13,370	*15,870	13,200	*12,100	8,700	*6,810	6,390	*6,560	4,980	*5,530	4,480	9.77 m
-3.0 m	kg	*16,040	*16,040	*13,080	*13,080	*10,290	8,660	*7,910	6,370	*5,260	5,050	*5,080	5,010	9.07 m
-4.5 m	kg			*8,930	*8,930	*7,180	*7,180	*4,900	*4,900			*3,650	*3,650	8.03 m

SK350LC		2 piece boom		Arm: 2.60 m		Bucket: without		Shoe: 600 mm (Heavy Lift)					
B	A	3.0 m		4.5 m		6.0 m		7.5 m		At max. reach		Radius	
9.0 m	kg			*14,100	*14,100					*11,940	*11,940	5.68 m	
7.5 m	kg			*14,020	*14,020	*7,550	*7,550			*10,480	8,290	7.15 m	
6.0 m	kg	*17,220	*17,220	*15,020	*15,020	*12,050	10,970	*7,170	*7,170	*9,750	6,690	8.08 m	
4.5 m	kg	*18,730	*18,730	*16,730	15,980	*12,700	10,380	*6,530	*6,530	9,100	5,860	8.65 m	
3.0 m	kg	*24,140	*24,140	*17,580	14,830	*13,250	9,730	*6,440	*6,440	8,520	5,460	8.94 m	
1.5 m	kg	*27,960	*27,960	*17,980	13,920	*13,240	9,220	*7,090	6,820	*8,050	5,330	8.97 m	
G.L.	kg	*25,280	*25,280	*15,550	13,550	*7,760	*7,760	*8,460	6,660	*7,370	5,480	8.74 m	
-1.5 m	kg	*13,790	*13,790	*12,520	*12,520	*10,510	8,940	*8,040	6,660	*6,360	5,980	8.23 m	
-3.0 m	kg			*8,540	*8,540	*7,370	*7,370			*4,620	*4,620	7.38 m	

SK350NLC		2 piece boom Arm: 3.30 m Bucket: without Shoe: 600 mm (Heavy Lift)												
B	A	3.0 m		4.5 m		6.0 m		7.5 m		9.0 m		At max. reach		Radius
														
10.5 m	kg			*9,280	*9,280							*8,430	*8,430	4.63 m
9.0 m	kg					*7,950	*7,950					*6,880	*6,880	6.70 m
7.5 m	kg					*11,010	10,790	*6,790	*6,790			*6,000	*6,000	7.98 m
6.0 m	kg			*11,880	*11,880	*11,440	10,460	*5,780	*5,780			*5,700	5,450	8.82 m
4.5 m	kg			*15,800	15,320	*12,220	9,890	*5,090	*5,090	*6,010	5,210	*5,610	4,860	9.35 m
3.0 m	kg	*25,710	*25,710	*17,600	13,830	*13,010	9,220	*4,970	*4,970	*6,110	5,060	*5,690	4,540	9.61 m
1.5 m	kg	*27,810	24,420	*18,080	12,760	*13,350	8,640	*5,520	*5,520	*6,410	4,910	*5,950	4,440	9.64 m
G.L.	kg	*22,850	*22,850	*16,900	12,320	*12,910	8,290	*6,850	6,150	*6,790	4,810	*6,410	4,530	9.43 m
-1.5 m	kg	*13,570	*13,570	*14,510	12,270	*11,540	8,160	*8,730	6,070			*6,210	4,870	8.96 m
-3.0 m	kg			*11,000	*11,000	*9,050	8,250	*6,670	6,160			*4,980	*4,980	8.19 m

SK350NLC		2 piece boom Arm: 4.15 m Bucket: without Shoe: 600 mm (Heavy Lift)												
B	A	3.0 m		4.5 m		6.0 m		7.5 m		9.0 m		At max. reach		Radius
														
10.5 m	kg					*6,110	*6,110					*5,800	*5,800	6.06 m
9.0 m	kg					*8,460	*8,460	*6,160	*6,160			*4,930	*4,930	7.75 m
7.5 m	kg					*8,600	*8,600	*5,270	*5,270			*4,530	*4,530	8.88 m
6.0 m	kg					*9,190	*9,190	*9,070	7,400	*5,200	*5,200	*4,360	*4,360	9.64 m
4.5 m	kg			*11,810	*11,810	*11,270	10,130	*9,470	7,090	*4,880	*4,880	*4,320	4,180	10.13 m
3.0 m	kg	*24,380	*24,380	*16,330	14,390	*12,240	9,380	*9,920	6,690	*4,820	*4,820	*4,400	3,920	10.37 m
1.5 m	kg	*27,360	24,350	*17,650	12,990	*12,910	8,670	*3,820	*3,820	*5,140	4,790	*4,600	3,810	10.39 m
G.L.	kg	*9,090	*9,090	*17,460	12,190	*12,930	8,170	*4,950	*4,950	*5,820	4,630	*4,950	3,870	10.20 m
-1.5 m	kg	*13,370	*13,370	*15,870	11,910	*12,100	7,910	*6,810	5,830	*6,560	4,550	*5,530	4,100	9.77 m
-3.0 m	kg	*16,040	*16,040	*13,080	11,950	*10,290	7,880	*7,910	5,810	*5,260	4,620	*5,080	4,580	9.07 m
-4.5 m	kg			*8,930	*8,930	*7,180	*7,180	*4,900	*4,900			*3,650	*3,650	8.03 m

SK350NLC		2 piece boom Arm: 2.60 m Bucket: without Shoe: 600 mm (Heavy Lift)												
B	A	3.0 m		4.5 m		6.0 m		7.5 m		At max. reach		Radius		
														
9.0 m	kg			*14,100	*14,100					*11,940	11,220			5.68 m
7.5 m	kg			*14,020	*14,020	*7,550	*7,550			*10,480	7,670			7.15 m
6.0 m	kg			*15,020	*15,020	*12,050	10,140			*9,750	6,180			8.08 m
4.5 m	kg	*17,220	*17,220	*16,730	14,610	*12,700	9,570	*6,530	*6,530	9,100	5,410			8.65 m
3.0 m	kg	*24,140	*24,140	*17,580	13,500	*13,250	8,930	*6,440	*6,440	8,520	5,020			8.94 m
1.5 m	kg	*27,960	25,050	*17,980	12,620	*13,240	8,430	*7,090	6,260	*8,050	4,900			8.97 m
G.L.	kg	*25,280	24,320	*15,550	12,260	*7,760	*7,760	*8,460	6,100	*7,370	5,040			8.74 m
-1.5 m	kg	*13,790	*13,790	*12,520	12,310	*10,510	8,160	*8,040	6,110	*6,360	5,490			8.23 m
-3.0 m	kg			*8,540	*8,540	*7,370	*7,370			*4,620	*4,620			7.38 m

Notes:

- Do not attempt to lift or hold any load that is greater than these lift capacities at their specified lift point radius and heights. Weight of all accessories must be deducted from the above lift capacities.
- Lift capacities are based on machine standing on level, firm, and uniform ground. User must make allowance for job conditions such as soft or uneven ground, out of level conditions, side loads, sudden stopping of loads, hazardous conditions, experience of personnel, etc.
- Arm top defined as lift point.
- The above lift capacities are in compliance with ISO 10567. They do not exceed 87% of hydraulic lift

- capacity or 75% of tipping load. Lift capacities marked with an asterisk(*) are limited by hydraulic capacity rather than tipping load.
- Operator should be fully acquainted with the Operator's and Maintenance Instructions before operating this machine. Rules for safe operation of equipment should be adhered to at all times.
- Lift capacities apply to only machine as originally manufactured and normally equipped by KOBELCO CONSTRUCTION MACHINERY CO., LTD.

Standard and Optional Equipment

● =Std ○ =Opt — =N/A

Category	Description	SK350(N)LC-11		
		Mono boom / 2 piece boom		
		LC	NLC	
ENGINE	HINO J08EYD-KSSA engine (EU Stage V compliant)	●	●	
	Exhaust DOC DPF SCR system	●	●	
	Alternator 24 V/60 A	●	●	
	Starter motor 24 V/5 kW	●	●	
	Batteries 2 x 120 Ah	●	●	
	Fan suction type cooling system	●	●	
	Auto deceleration function	●	●	
	Auto Idle Stop (AIS)	●	●	
HYDRAULIC SYSTEM	3 work modes H,S,Eco	●	●	
	Power Boost (37.8 MPa)	●	●	
	Heavy lift mode	●	●	
	Pressure release function	●	●	
	Independent travel function	●	●	
	Auto warm up system	●	●	
	Proportional Hand Control (for E&N&B piping)	●	●	
	Hydraulic oil VG32	●	●	
	Hydraulic oil VG46	○	○	
	Hydraulic oil VG68	○	○	
	PIPING	E&N&B piping	●	●
		E&N&B piping + Bigger capacity P4 pump (93.9 L/min)	○	○
Standard piping (only mono boom spec)		○	—	
QH piping		●	●	
CABIN	Air suspension seat with heating	●	●	
	10-inch colour monitor	●	●	
	LED door light	●	●	
	Air-conditioner	●	●	
	DAB+ radio (FM/AM & AUX & USB & Bluetooth* & hands-free telephone)	●	●	
	Harness for CAB four lights and CAB yellow flasher	●	●	
	Parallel wiper	●	●	
	12 V power supply	●	●	
	Rain visor	○	○	
	Sun screen	○	○	
LIGHTS	LED work lights; 2 on boom & 1 on upper frame	●	●	
	LED work lights; 2 on Cab top front	○	○	
WORKING EQUIPMENT	Standard boom (6.50 m)	●	●	
	2 Piece Boom	○	○	
	Standard HD arm (3.30 m) with rock guard	●	●	
	Short HD arm (2.60 m) with rock guard	○	○	
	Long HD arm (4.15 m) with rock guard	○	○	
	OHK hook	●	●	
COUNTERWEIGHT	Semi heavier C/W (TTL 8,590 kg)	●	●	
UNDERCARRIAGE	600 mm steel shoe	●	●	
	600 mm double grouser shoe	○	○	
	700 mm steel shoe	○	○	
	800 mm steel shoe	○	—	
	900 mm steel shoe	○	—	
	Track guide (one per side)	●	●	
	Additional track guides (two additional per side)	○	○	
	Lower frame guard	●	●	
SAFETY	Engine emergency stop switch	●	●	
	Pump emergency mode (KPSS release switch)	●	●	
	Emergency accel dial	●	●	
	Emergency manual valve for lowering attachment	●	●	
	Over load alarm	●	●	
	Safety valve for boom & arm cylinder	●	●	
	ROPS compliant cab (ISO 12117-2:2008)	●	●	
	OPG Level II top guard (ISO 10262:1998)	●	●	
	OPG Level II front guard (ISO 10262:1998)	○	○	
	Eagle-eye view camera (Rear, Right, Left)	●	●	
	Seatbelt indicator on display	●	●	
	Travel alarm	○	○	
	Extended guard rail	○	○	
	OTHERS	Refuelling pump	●	●
		Harness for engine room light	●	●
Ral color		○	○	
KOMEXS		●	●	

*The air conditioning system on this machine contains fluorinated greenhouse gas HFC-134a (GWP 1430). Quantity of gas 0.9 kg (CO₂ equivalent 1.3 t).
Note: Bluetooth* is a registered trademark of the Bluetooth SIG Inc.

SK350_{LC}
SK350LC-11

SK350_{NLC}
SK350NLC-11

SK350_{LC}
SK350LC-11

SK350_{NLC}
SK350NLC-11

Note: This catalogue may contain attachments and optional equipment that are not available in your area. And it may contain photographs of machines with specifications that differ from those of machines sold in your areas. Please consult your nearest KOBELCO distributor for those items you require.
Specialist equipment is needed to use this machine in demolition work. Before using it please contact your KOBELCO dealer.
Due to our policy of continuous product improvements all designs and specifications are subject to change without advance notice.
Copyright by **KOBELCO CONSTRUCTION MACHINERY CO., LTD.** No part of this catalogue may be reproduced in any manner without notice.

KOBELCO CONSTRUCTION MACHINERY EUROPE B.V.

Veluwezoom 15
1327 AE Almere
The Netherlands
www.kobelco-europe.com

Enquiries To: