

Compact Class

SUPER 1000i

TRACKED PAVER



Maximum pave width 3.9 m
Maximum laydown rate 270 tonnes/h
Transport width 1.85 m



Powerful, economical and quiet



The **SUPER 1000i** is a particularly compact paver that is cost-efficient in every respect. A member of the Classic Line, it features a range of functions which is focussed on the essentials required by paving teams for successful operations.

VÖGELE's Classic Line machines are equipped with the ErgoBasic operating system. It was developed on the basis of the proven ErgoPlus 3 operating system, but tailored specifically to the requirements of Classic Line machine users. As with ErgoPlus 3, the design of the paver operator's ErgoBasic console is so clear that all functions can be grasped quickly and operated securely.

The SUPER 1000i can be combined with the AB 340 Extending Screed with vibrators (V version) or with tamper and vibrators (TV version). Thanks to its range of pave widths extending from 0.75 m to 3.9 m, the paver is ideally suited to the construction or rehabilitation of combined footpaths and cycle paths, farm tracks, minor roads and small areas.

Highlights of the SUPER 1000i



Tracked Compact Class paver with a wide range of applications and pave widths up to 3.9 m

Powerful diesel engine of the latest generation

Simple operation with the innovative and easy-to-grasp ErgoBasic operating concept

Crawler tracks with maximum traction and traction drives in controlled loops

Simple service concept perfectly tailored to the requirements of workshop and service staff

Can be combined with the AB 340 Extending Screed in the V and TV versions

Compact dimensions for paving in very tight spaces



Small size, high efficiency: be it extremely confined job sites outside of town or winding inner-city alleyways, the highly manoeuvrable VÖGELE Compact Class pavers can negotiate tight spots with ease while delivering top performances.



» **The slim paver design,** with no protruding edges and a compact overall length, makes it very easy to work and manoeuvre on tight job sites.

» **The clearance width** of just 1.85 m allows the SUPER 1000i to easily get in and out of confined spaces such as narrow alleys. The push-rollers automatically fold up together with the hopper sides.

» **For transport,** the hardtop, made of a glass fibre-reinforced polymer material, and the exhaust pipe can be folded down in just a few swift moves, readying the paver for transport quickly and easily.



Range of applications of the VÖGELE Compact Class

With their combination of compact dimensions and top performance, road pavers in the VÖGELE Compact Class can handle a wide variety of applications.

Whether it is a combined footpath and cycle path, a farm track or minor roads and small areas, the SUPER 1000i is more than up to the task, thanks to its wide range of pave widths from 0.75 m to 3.9 m and its innovative drive concept.



ASPHALT PAVING ON COMBINED FOOT AND CYCLE PATHS



SURFACING PATHS IN PUBLIC PARKS

The applications illustrated here are typical of the VÖGELE Compact Class.

The drive concept – efficiency, performance and low consumption



VÖGELE's modern drive concept guarantees full power whenever it is needed and, thanks to its superior technology, this Compact Class paver is exceedingly economical in everyday use.

This is achieved by means of intelligent engine management with ECO mode and a variable-speed fan. These features significantly reduce the SUPER 1000i's fuel consumption and noise emissions.

The high-traction crawler tracks on the SUPER 1000i perfectly combine high performance paving with maximum mobility during transport.

Full power – intelligent technology

Three main components form the power unit of the SUPER 1000i: the large cooler assembly, an advanced, liquid-cooled diesel engine and a splitter gearbox flanged directly to the engine.

The driving force behind this VÖGELE powerhouse is a powerful diesel engine. The 4-cylinder engine delivers 55,4 kW at 2,000 rpm, though fuel-saving ECO mode is sufficient for many applications. Moreover, the machine operates particularly quietly when running at just 1,600 rpm.

A large cooler assembly ensures that the power unit always delivers its full output. With innovative air routing and a variable-speed fan, temperatures

are continuously maintained within the optimum range, significantly extending the service life of both the diesel engine and the hydraulic oil. Another advantage is that the machine can be operated without difficulty in all climatic regions around the world.

All hydraulic consumers are directly supplied with hydraulic oil via the splitter gearbox. Hydraulic pumps and valves are centrally located, making them optimally accessible for servicing.



The power unit of the SUPER 1000i with diesel oxidation catalyst (DOC) and diesel particulate filter (DPF) for exhaust gas after-treatment complies with the strict requirements of European exhaust emissions standard Stage V and US EPA Tier 4f.



The large cooler assembly is made up of four parts. It ensures that charge air, engine coolant, fuel and hydraulic oil are maintained at optimum temperature.

- » **Powerful diesel engine** develops 55,4 kW at just 2,000 rpm.
- » **ECO mode at 1,600 rpm** is not only perfectly adequate for many applications, it also cuts operating costs and supports super-quiet operation.
- » **The sophisticated exhaust gas after-treatment of the engine** complies with the strict requirements of European emissions standard Stage V as well as US EPA standard Tier 4f.
- » **A powerful three-phase AC generator** with generator management controls output in line with the selected pave width and minimizes the time required to heat the compacting systems up to operating temperature.

Efficient transmission of engine power

Thanks to high-quality separate hydraulic drives, our pavers operate extremely cost-efficiently at a high performance level. With its powerful crawler tracks, the SUPER 1000i has no problem pushing feed vehicles or working at a wide pave width on a soft base.

In terms of traction, too, the VÖGELE drive concept for tracked pavers leaves nothing to be desired.



» **The hydraulic systems** for the traction drive, conveyors and augers as well as the compacting systems all operate in separate closed circuits for maximum efficiency.

» **Long crawler tracks** deliver maximum traction thanks to their large footprint. This ensures a constant forward speed even when operating on difficult terrain.

» **Positive tracking when moving straight** and accurate cornering due to electronically controlled separate drives provided for both crawler tracks.

» **Powerful separate drives**, installed in the sprockets of the crawler tracks, translate engine output into pave speed with no loss of power.



Perfect material management for perfect paving quality



A continuous flow of mix is key to ensuring uninterrupted and high-quality paving. That is why we attach such importance to professional material management when designing our pavers.

All our development efforts focus on simple operation and the best possible overview for the paving team.

Easy and clean feeding with mix

Should material feeding become difficult on confined job sites, the large volume of the SUPER 1000i's material hopper guarantees that the screed can still be optimally supplied with mix.

Separately folding hydraulic hopper sides ensure smooth feeding with mix, even when paving across asymmetrical widths and along boundaries.



- » **Oscillating push-rollers** for convenient and shock-free docking also of large feed vehicles.
- » **The large material hopper** has a capacity of 10 t so that a sufficient quantity of mix is available for paving at all times, even in situations where feeding is difficult, such as when paving under bridges.
- » **Separately folding hydraulic hopper sides** for smooth feeding with mix, paving along boundaries and a targeted mix supply even when paving across asymmetrical widths.

Perfect conveying and spreading of mix, just like the big pavers

The conveyance and even spreading of mix in front of the screed are optimal thanks to the large conveyor tunnel, proportional control of conveyors and powerful augers.

What is more, the height-adjustable augers and folding limiting plates for the auger tunnel allow the paver to be repositioned without a need for conversion, a benefit that saves time and money.

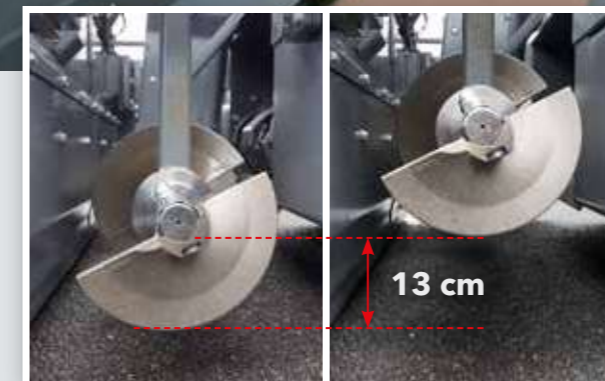

The height of the augers is infinitely variable by 13 cm for uniform spreading of mix across the entire pave width.

- » **The amply dimensioned conveyor tunnel** and powerful, separate hydraulic drives for conveyors and augers support laydown rates of up to 270 t/h, which are extraordinarily high for a paver in this class.
- » **Separate drives and controls** are installed for each conveyor and auger. When operating in Automatic mode, conveyors and augers are subject to continual monitoring. Proportional control provides for a constant head of mix in front of the screed.

The ErgoBasic operating concept



The **ErgoBasic operating concept** was developed on the basis of the proven ErgoPlus operating system which is installed in our Premium Line pavers, but was tailored specifically to the needs and requirements of VÖGELE Classic Line users.

The goal was to develop an operating system that can be operated just as quickly, accurately and intuitively as the ErgoPlus 3 system on the "Dash 3" machines.

This makes VÖGELE the only manufacturer to offer a standardized operating concept for all paver classes.



The paver operator's
ErgoBasic console

“Full control for the machine operator!”

The paver operator's ErgoBasic console

Everything at a glance: the functions are arranged in a clear, logical and practical layout that has clearly been inspired by the ErgoPlus operating console. The type of controls and the symbols used are all in line with those on an ErgoPlus console. Given the limited number of functions, there is no need for a display.

The status of all settings is indicated as a percentage on LED strips immediately next to the relevant functions.

Additional LEDs indicate the set speeds of the augers and the compacting systems as well as the fill level of the diesel tank.



Function and status indicators

The function and status indicators mean that the operator always has full control over his machine. He can, for instance, read the fill level of the fuel tank directly and identify whether there are any functional faults.



Choice of operating modes for the paver

All the main paving and machine functions can be controlled directly by individual push-buttons on the paver operator's ErgoBasic console. The paver changes between operating modes at the push of a button in the following order: "Pave", "Positioning", "Job Site" and "Neutral". An LED indicates which mode is selected. On leaving "Pave" mode, the memory function stores all the most recent settings. After moving on the job site, the previously used paving parameters are instantly restored.



Speed of the augers

In Automatic mode, the plus/minus buttons can be used to adjust the maximum auger speed separately for the right and left sides to suit the pave width, without the use of sonic sensors. The value, which is set in percent, is indicated by the LEDs.



Safe operation during the night

The paver operator's ErgoBasic console features glarefree backlighting so that the paver operator can also work safely on night-time jobs.

Compacting effort

The speed of the compacting systems can be set directly on the paver operator's ErgoBasic console. The LED strips from 0 to 100% indicate the speed settings for the tamper and vibrators, enabling them to be adjusted immediately if required.

Steering at a pre-set angle

The machine is steered by means of an easy-grip rotary controller which enables the driver to manoeuvre the machine easily and precisely even in the tightest spots. For long bends with a constant radius, the desired steering angle can be preselected using arrow keys. The paver then automatically follows the set path until the function is deactivated, allowing the driver to monitor the paving process undisturbed.

Idling function

Idling function is provided for the warm-up or cleaning of conveyors, augers and tamper.

The **ErgoBasic** remote control unit for the screed

The **safe and easy handling** of all screed functions is a key factor in high-quality pavement construction. That's why an ErgoBasic remote control unit for the screed was developed specifically for the new Classic Line pavers.

Its keypad is laid out logically according to the functional processes. Designed for robustness, it is well able to withstand tough job-site conditions.

Operation is easy to understand and can be learned intuitively in a very short space of time, not least because the symbols used in the proven ErgoPlus operating system are found here, too.

The ErgoBasic remote control unit for the screed allows all paving-related functions to be set quickly and easily. This includes direct access to the material handling systems and the sonic sensors for the augers.

All the main paving functions can be controlled using the two handy remote control units for the screed. Simple, language-neutral symbols allow the machine to be operated intuitively.



- 1 // **Conveyor setting**
automatic/manual
- 2 // **Horn**
- 3 // **Auger setting**
automatic/manual/reverse
- 4 // **Screed floating** on/off
- 5 // **Adjustment of screed width**
one side
- 6 // **Adjustment of screed tow point ram**



The operator's Niveltronic Basic console

VÖGELE has also developed a System for Automated Grade and Slope Control to match the ErgoBasic operating concept: Niveltronic Basic. It is completely integrated into the machine control system and therefore perfectly adapted to the respective paver model. Another outstanding aspect of Niveltronic Basic is its particularly simple and intuitive handling, a feature which makes it easy even for less experienced operators to learn their way around the system. This creates ideal conditions for the Classic Line pavers to work true to line and level on any base.

Each side of the screed is operated by a separate compact and exceedingly robust Niveltronic Basic remote control unit.

A variety of sensor types is available for Niveltronic Basic, in keeping with the machine's large and varied range of uses. The selection extends from mechanical sensors to non-contacting sonic sensors. The System for Automated Grade and Slope Control can simultaneously be connected to two grade sensors and one slope sensor. The type of sensor used is detected automatically.

The kind of reference – ground, tensioned wire or transverse slope – can be easily set on the remote control unit.

The remote control units cover all the functions required for high-precision grade and slope control. Clear symbols support intuitive machine operation.



- 1 // **Deviation** from specified values
- 2 // **Niveltronic Basic** on/off
- 3 // **Setting** for sensor sensitivity
- 4 // **Selection of scanning mode** for the sensor (ground/tensioned wire/transverse slope)
- 5 // **Quick set-up**
- 6 // **Setting** of the specified value
- 7 // **Sensor calibration**





Paver operator's ErgoBasic platform

1. The comfortable paver operator's platform

gives an unobstructed view of all crucial areas on the paver such as material hopper, steering guide or screed. The paver operator is thus ideally positioned to monitor the material feeding process right from his seat.

2. Working comfortably

The operating console can be shifted across the entire working width so that operators can work comfortably and in an ergonomic position on either side of the machine.

3. A place for everything and everything in its place

The paver operator's platform is streamlined and well organized, offering the paver operator a professional workplace. The paver operator's console can be protected by a shatter-proof cover to prevent wilful damage.

4. Hardtop provides excellent protection

The modern hardtop, made of a glass fibre-reinforced polymer material, protects the operator. It can easily be collapsed to quickly prepare the paver for transport.

5. Cost-efficient and service-friendly design

The paver operator has convenient access to all service points on the machine. All hydraulic pumps connected to the transfer gearbox are extremely easy to service thanks to their clear arrangement and easy accessibility. Durable components made of highly wear-resistant materials for a long service life minimize machine downtimes.

6. Safe and convenient step

The walkway and convenient central step on the screed ensure safe and convenient access to the operator's platform.

7. Safe and simple operation of all screed functions

All paving-related functions can be set quickly and easily on the ErgoBasic remote control unit for the screed.

8. Protection against theft and vandalism

Once work has been completed, the remote control unit for the screed can be collapsed and secured.



AB 340 Extending Screed

The **AB 340 Extending Screed** is optionally available for the SUPER 1000i with vibrators only (V version) or with tamper and vibrators (TV version). With this screed, rehabilitation jobs can be carried out very quickly and easily without ever compromising on quality.

The **unique VÖGELE** single-tube telescoping system enables the screed width to be adjusted up to 3.4 m with millimetre precision and zero slack.

A **typical VÖGELE** feature also found in the AB 340 Extending Screed is its powerful electric heating system. This modern heating system quickly and uniformly heats the screed up to operating temperature, ensuring a smooth surface texture.

Excellent insulation of the screed plates reduces loss of heat to a minimum and ensures that heating the screed only takes a short time, even with the engine running at minimum rpm.

The SUPER 1000i screed system

AB 340

Pave widths

- » Infinitely variable range from 1.8 m to 3.4 m
- » Maximum pave width with bolt-on extensions:
 - > 3.9 m (2 x 25 cm)
- » Minimum pave width of 0.75 m with the system for pave width reduction

Compacting systems

- » AB 340 V Extending Screed with vibrators
- » AB 340 TV Extending Screed with tamper and vibrators



AB 340

AB 340 Extending Screed with 25 cm bolt-on extensions

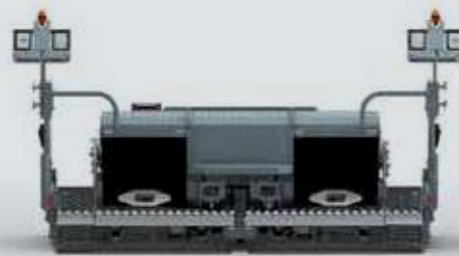

Easy transport
*Even with bolt-on extensions and side plates fitted, the transport dimensions do not exceed 2.55 m.

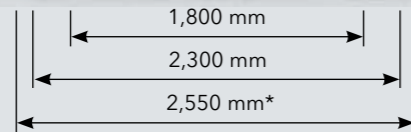

AB 340

Extended to maximum pave width

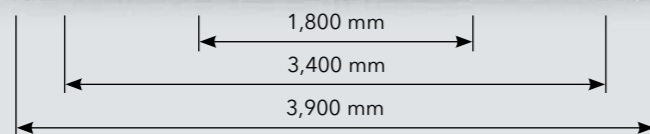

All the facts at a glance

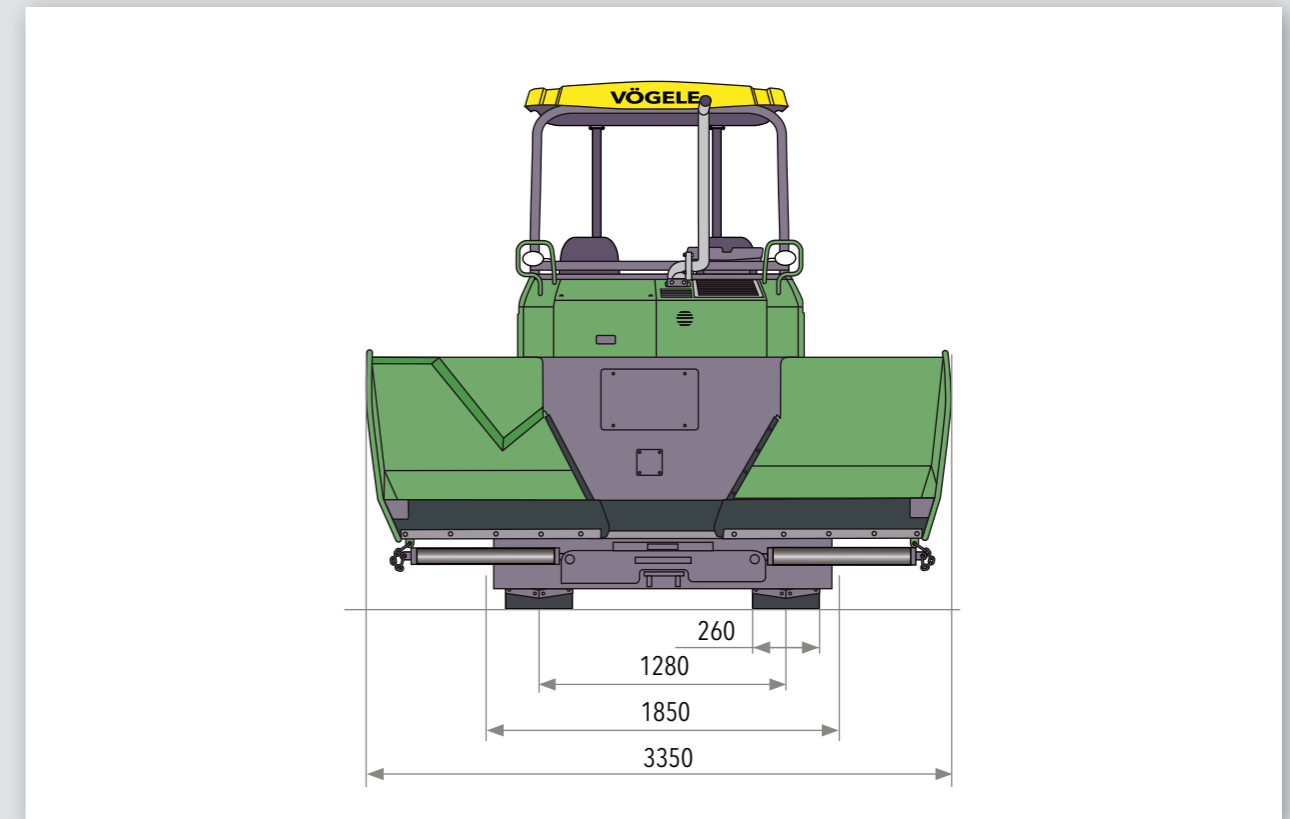
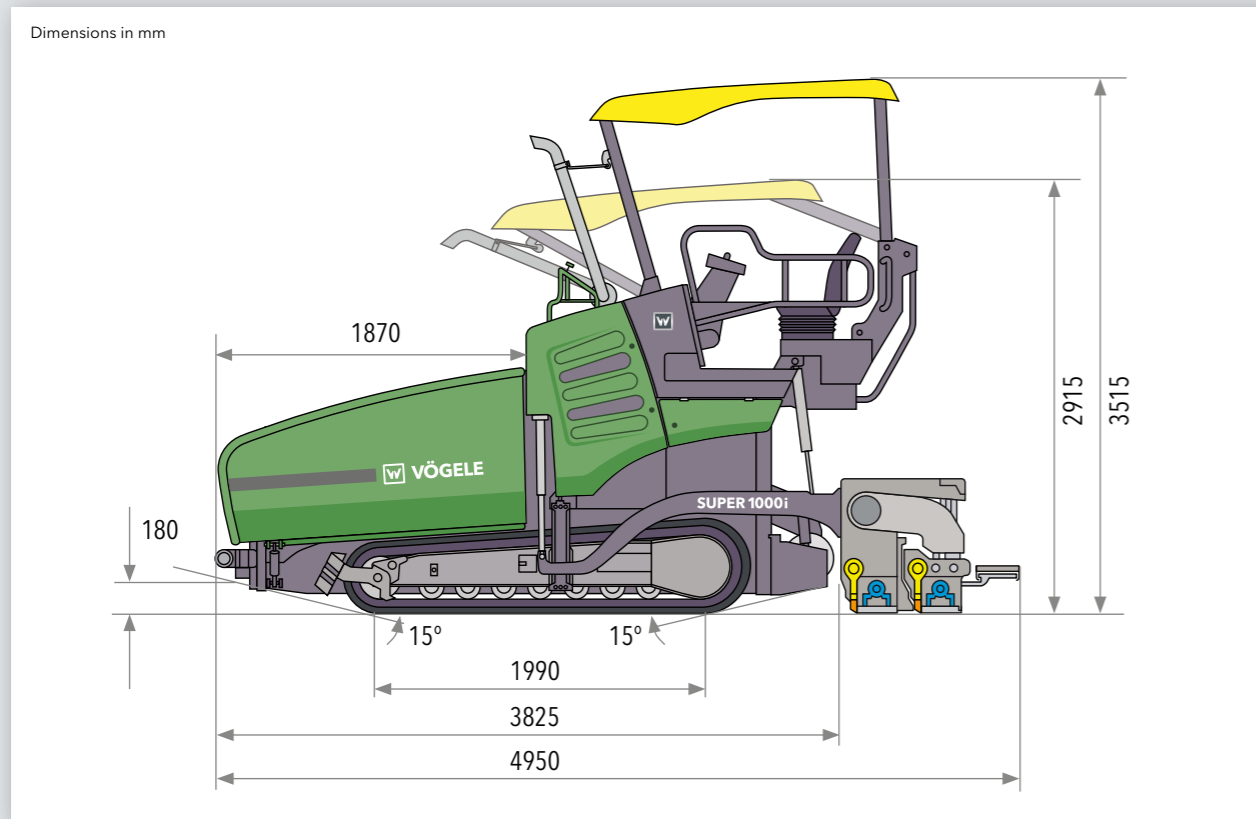

Power unit	
Engine	4-cylinder diesel engine
Manufacturer	Deutz
Type	TCD 3.6 L4
Output	
Nominal	55,4 kW at 2,000 rpm (according to DIN)
ECO mode	55,4 kW at 1,600 rpm
Exhaust emissions standards	
Exhaust gas after-treatment	EU Stage V, US EPA Tier 4f DOC, DPF
Emission data	
Sound power level	≤104 dB(A) (2000/14/EC and DIN EN 500-6)
Daily noise exposure level	>80 dB(A) (DIN EN 500-6)
Fuel tank	
	110 litres

Undercarriage	
Crawler tracks	with rubber pads
Ground contact	1,990 x 260 mm
Track tension adjuster	spring assembly
Lubrication of track rollers	lifetime
Traction drive	
	electronically controlled separate hydraulic drive provided for each crawler track
Speeds	
Paving	up to 18 m/min., infinitely variable
Transport	up to 4.5 km/h, infinitely variable
Material hopper	
Hopper capacity	10 t
Width	3,350 mm
Feed height	580 mm (bottom of receiving hopper)
Push-rollers	
Position	oscillating can be displaced forwards by 80 mm

Conveyors and augers	
Conveyors	
Conveyors	2, with replaceable feeder bars, direction of conveyor temporarily reversible
Drive	separate hydraulic drive provided for each conveyor
Speed	up to 21 m/min., infinitely variable (manual or automatic)
Augers	
Augers	2, with replaceable auger blades, auger rotation reversible
Diameter	300 mm
Drive	separate hydraulic drive provided for each auger
Speed	up to 85 rpm, infinitely variable (manual or automatic)
Auger height	
Standard	infinitely variable by 13 cm, mechanical
Option	infinitely variable by 13 cm, hydraulic

Screed		
AB 340	basic width	1.8 to 3.4 m
	maximum width	3.9 m
	min. pave width with system	
	for pave width reduction	0.75 m
	reduction in width by cut-off shoes 2x52.5 cm compacting systems	V, TV
Layer thickness		
		up to 15 cm
Screed heating		
		electric by heating rods
		Power supply three-phase AC generator
Dimensions (transport) and weights		
Length		paver with screed
	AB 340	4.95 m
Weights		
		paver with screed
	AB 340 V	10,050 kg
	AB 340 TV	10,250 kg

Key: DOC = diesel oxidation catalyst DPF = diesel particulate filter AB = extending screed V = with vibrators TV = with tamper and vibrators

Subject to technical changes.



Your VÖGELE QR Code will take you straight to the "SUPER 1000i" on our website.



JOSEPH VÖGELE AG

Joseph-Vögele-Str. 1
67075 Ludwigshafen · Germany
www.voegele.info

T: +49 621 / 81 05 0
F: +49 621 / 81 05 461
marketing@voegele.info



® ERGOPLUS, InLine Pave, NAVITRONIC, NAVITRONIC Basic, NAVITRONIC Plus, NIVELTRONIC, NIVELTRONIC Plus, RoadScan, SprayJet, VÖGELE, VÖGELE PowerFeeder, PaveDock, PaveDock Assistant, AutoSet, AutoSet Plus, AutoSet Basic, ErgoBasic and VÖGELE-EcoPlus are registered Community Trademarks of JOSEPH VÖGELE AG, Ludwigshafen/Rhein, Germany. PCC is a registered German Trademark of JOSEPH VÖGELE AG, Ludwigshafen/Rhein, Germany. ERGOPLUS, NAVITRONIC Plus, NAVITRONIC BASIC, NIVELTRONIC Plus, SprayJet, VISION, VÖGELE, VÖGELE PowerFeeder, PaveDock, PaveDock Assistant, AutoSet, AutoSet Plus, AutoSet Basic and VÖGELE-EcoPlus are trademarks registered in the US Patent and Trademark Office to JOSEPH VÖGELE AG, Ludwigshafen/Rhein, Germany. Legally binding claims cannot be derived from written information or pictures contained in this brochure. We reserve the right to make technical or design alterations. Pictures may include optional extras.