

KOMATSU®

WA380z-6

HORSEPOWER

Gross: 143 kW 192 HP @ 2100 min⁻¹

Net: 141 kW 189 HP @ 2100 min⁻¹

BUCKET CAPACITY

2.7–4.0 m³

WA
380z

WHEEL LOADER



Photos may include optional equipment.

WALK-AROUND

High Productivity & Low Fuel Consumption

- High performance SAA6D107E-1 engine
- Low fuel consumption
- Dual-mode engine power select system
- Automatic transmission with shift timing select system
- Variable displacement piston pump & CLSS

See pages 4 and 5.

Excellent Operator Environment

- Automatic transmission with ECMV
- Electronically controlled transmission lever
- Variable transmission cut-off system
- Tilt steering column
- Fingertip control levers
- Pillar-less large ROPS/FOPS cab-integrated
- Easy entry/exit, rear-hinged doors

See pages 8 and 9.



Harmony with Environment

- EPA Tier 3 and EU Stage 3A emissions certified
- Low fuel consumption

Increased Reliability

- Reliable Komatsu designed and manufactured components
- Sturdy main frame
- Maintenance-free, fully hydraulic, wet disc service and parking brakes
- Hydraulic hoses use flat face O-ring seals
- Cation electrodeposition process is used to apply primer paint
- Powder coating process is used to apply on main structure
- Sealed DT connectors for electrical connections

See page 6.

HORSEPOWER

Gross: 143 kW 192 HP @ 2100 min⁻¹

Net: 141 kW 189 HP @ 2100 min⁻¹

BUCKET CAPACITY

2.7–4.0 m³



Easy Maintenance

- “EMMS” (Equipment Management Monitoring System)
 - Engine side doors open wide
- See page 7.

HIGH PRODUCTIVITY AND LOW FUEL CONSUMPTION



High Performance SAA6D107E-1 Engine

Electronic Heavy Duty Common Rail fuel injection system provides optimum combustion of fuel. This system also provides fast throttle response to match the machine's powerful tractive effort and fast hydraulic response.

Net: 141 kW 189 HP

Low Emission Engine

This engine is EPA Tier 3 and EU Stage 3A emissions certified, without sacrificing power or machine productivity.

Low Fuel Consumption

The fuel consumption is reduced greatly because of the low-noise, high-torque engine and the large-capacity torque converter with maximum efficiency in the low-speed range.

Dual-mode Engine Power Select System

This wheel loader offers two selectable operating modes—E and P. The operator can adjust the machine's performance with the selection switch.

- **E Mode:** This mode provides maximum fuel efficiency for most of general loading.
- **P Mode:** This mode provides maximum power output for hard digging operation or hill climb.



Dual mode engine power selection switch



The ECO indicator will help an operator to promote energy saving.

Automatic Transmission with Mode Select System

This operator controlled system allows the operator to select manual shifting or two levels of automatic shifting (low and high). Auto L mode is for fuel saving operation with the gear shift timing set at lower speeds than Auto H mode. Therefore Auto L mode keeps the engine run in a relatively low rpms range



Shift mode selection switch

for fuel conservation while yielding adequate tractive force by depressing the accelerator pedal.

Variable Displacement Piston Pump & CLSS

New design variable displacement piston pump combined with the Closed-center Load Sensing System delivers hydraulic flow just as the job requires preventing wasting hydraulic pressure. Minimized waste loss contributes to better fuel economy.

- **New Variable Displacement Piston Pump:** The pump delivers only necessary amounts minimizing waste loss.

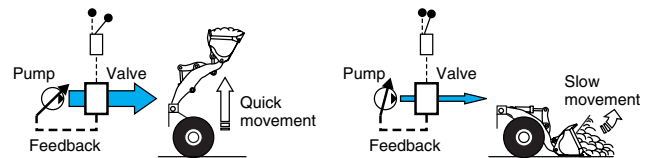

- **Fixed Displacement Piston Pump:** The pump delivers the maximum amount at any time and the unused flow is disposed.

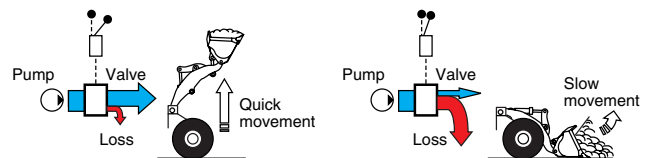



Maximum Dumping Clearance and Reach

The long lift arms provide high dumping clearances and maximum dumping reach. The operator can even level loads on the body of a dump truck easily and efficiently.

Dumping Clearance: 2825 mm

Dumping Reach: 1240 mm
(3.1 m³ bucket with Teeth)



INCREASED RELIABILITY

Komatsu Components

Komatsu manufactures the engine, torque converter, transmission, hydraulic units, electric parts, and even each bolt on this wheel loader.

Komatsu loaders are manufactured with an integrated production system under a strict quality control system.

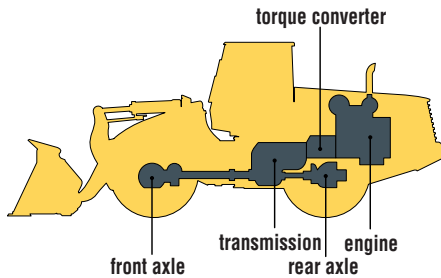

Wet Multi-disc Brakes and Fully Hydraulic Braking System

mean lower maintenance costs and higher reliability. Wet disc brakes are fully sealed. Contaminants are kept out, reducing wear and resulting maintenance. Brakes require no adjustments for wear, meaning even lower maintenance. The new parking brake is also an adjustment-free, wet multi-disc for high reliability and long life.

Added reliability is designed into the braking system by the use of two independent hydraulic circuits. Provides hydraulic backup should one of the circuits fail.

Fully hydraulic brakes mean no air system to bleed, or the condensation of water in the system that can lead to contamination, corrosion, and freezing.

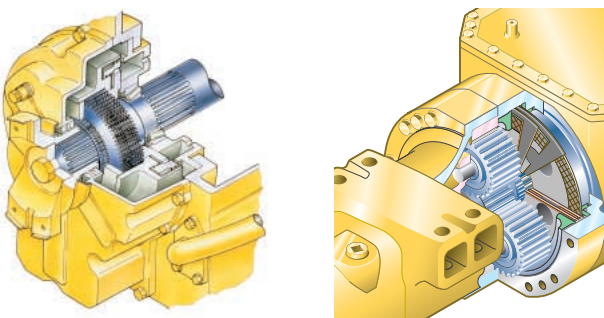

High-rigidity Frames and Loader Linkage

The front and rear frames and the loader linkage have got more torsional rigidity to secure resistance against stresses increased due to the use of a larger bucket.

Frame and loader linkage are designed to accommodate actual working loads, and simulated computer testing proves its strength.

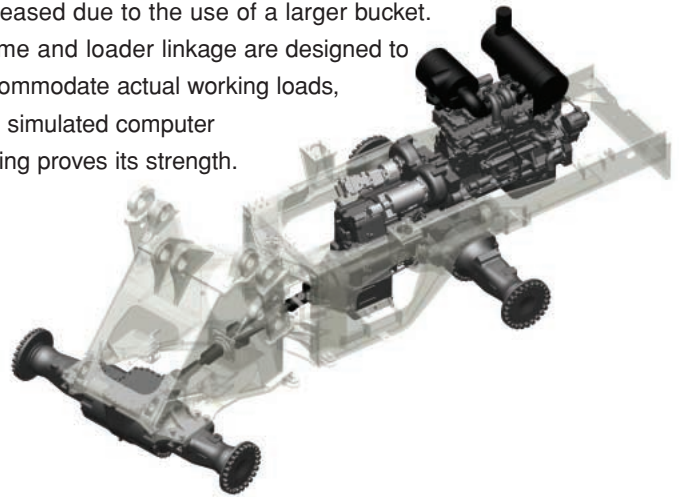

Flat Face-to-face O-ring Seals

Flat face-to-face O-ring seals are used to securely seal hydraulic hose connections and to prevent oil leakage.

In addition, buffer rings are installed to the head side of the all-hydraulic cylinders to lower the load on the rod seals and maximize the reliability.

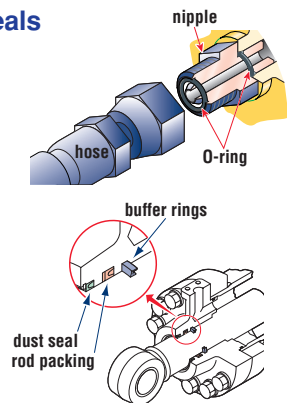

Cation Electrodeposition Primer Paint/ Powder Coating Final Paint

Cation electrodeposition paint is applied as a primer paint and powder coating is applied as topcoat to the exterior metal sheet parts. This process results in a beautiful rust-free machine, even in the most severe environments. Some external parts are made of plastic providing long life and high impact resistance.

Sealed DT Connectors

Main harnesses and controller connectors are equipped with sealed DT connectors providing high reliability, water resistance and dust resistance.



EASY MAINTENANCE



EMMS (Equipment Management Monitoring System)

Monitor is mounted in front of the operator for easy view, allowing the operator to easily check gauges and warning lights.



A specially designed two-spoke steering wheel allows the operator to easily see the instrument panel.

Maintenance Control and Troubleshooting Functions

- **Action code display function:** If the loader has any troubles, the monitor displays action details on the character display at the center bottom of the monitor.
- **Monitor function:** Controller monitors engine oil level, pressure, coolant temperature, air cleaner clogging, etc. If controller finds abnormalities, all of these are displayed on LCD.
- **Replacement time notice function:** Monitor informs replacement time of oil and filters on LCD when it reaches replacement intervals.
- **Trouble data memory function:** Monitor stores abnormalities for effective troubleshooting.

Engine Side Doors Open Wide

The operator can open and close each engine side door easily with the assistance of a gas spring to perform daily service checks from the ground.



Upper stop position



Lower stop position

OPERATOR ENVIRONMENT

Easy Operation

Automatic Transmission with ECMV

Automatic transmission with ECMV automatically selects the proper gear speed based on travel speed, engine speed, and other travel conditions. The ECMV (Electronically Controlled Modulation Valve) system engages the clutch smoothly to prevent lags and shocks when shifting. This system provides efficient machine operation and a comfortable ride.

- **Kick-down switch:**

Consider this valuable feature for added productivity. With the touch of a finger, the kick-down switch

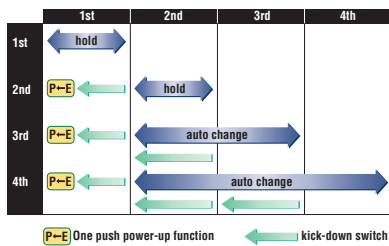

automatically downshifts from second to first when beginning the digging cycle. It automatically upshifts from first to second when the direction control lever is placed in reverse. This results in increased rim pull for better bucket penetration and reduced cycle times for higher productivity.

- **One push power-up function:** The kick-down switch also functions as a power-up switch in first gear. The first time the kick-down switch is depressed it functions as a kick-down switch and gear speed is reduced. When the machine is in E operation mode and first gear, pressing the kick-down switch a second time changes the operation mode to P allowing increased power for heavy digging operation. The operation mode returns to E when machine gear speed changes or direction changes to reverse.
- **Hold switch:** Auto shift is selected and if the operator turns on this switch when the lever is at the 3rd or 4th gear speed position, the transmission is fixed to that gear speed.

Electronically Controlled Transmission Lever



Easy shifting and directional changes

with Komatsu two-lever electronic shifting. Change direction or shift gears with a touch of the fingers without removing the

shifting hand from the steering wheel. Solid state electronics and conveniently located direction and gear shift controls make this possible. Automatic shifts in ranges two through four keep production high and manual shifting at a minimum.

Variable Transmission Cut-off System

The operator can continuously adjust the transmission cut-off pressure desired for the left brake pedal using switch located on the right-side control panel. The operator can improve the working performance by setting the cut-off pressure properly depending on working condition.

- High cut-off pressure for digging operations.
- Low cut-off pressure for truck-loading operations.



1:Cut-off ON/OFF switch 2:Cut off adjustment switch
3:Boom control 4:Bucket control



Fingertip Work Equipment Control Levers with Large Size Arm Rest

New PPC control levers are used for the work equipment. The operator can easily operate the work equipment with fingertip control, reducing operator fatigue and increasing



controllability. The large size arm rest can be adjusted up or down to provide the operator with a variety of comfortable operating positions.

Tilt Steering Column

The operator can tilt the steering column to provide a comfortable working position.



Pillar-less Large Cab



A wide pillar-less flat glass provides excellent front visibility. The wiper arm covers a large area to provide great visibility even on rainy days. The cab area is the largest in its class providing maximum space for the operator.

Increased seat reclining and slide adjustment to backward by introducing front mounted air conditioner unit.

The large cab is mounted with Komatsu's unique ROPS/FOPS viscous mounts. The hydraulically driven fan, and hydraulic pumps are mounted with rubber cushions, and the cab sealing is improved to provide a quiet, low-vibration, dustproof with pressurizing, and comfortable operating environment.

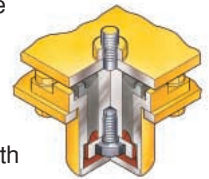

Rear-hinged Full Open Cab Doors

The cab door hinges are installed to the rear side of the cab providing a large opening angle for the operator to enter and exit. The steps are designed like a staircase, so that the operator can get on and off the cab easily.



SPECIFICATIONS



ENGINE

ModelKomatsu SAA6D107E-1
 TypeWater-cooled, 4-cycle
 AspirationTurbocharged, aftercooled
 Number of cylinders6
 Bore x stroke107 mm x 124 mm
 Piston displacement6.69 L
 GovernorAll-speed, electronic
 Horsepower
 SAE J1995Gross 143 kW 192 HP
 ISO 9249/SAE J1349*Net 141 kW 189 HP
 Rated rpm2100 min⁻¹
 Fan drive method for radiator coolingHydraulic
 Fuel systemDirect injection
 Lubrication system:
 MethodGear pump, force-lubrication
 FilterFull-flow type
 Air cleanerDry type with double elements and
 dust evacuator, plus dust indicator

*Net horsepower at the maximum speed of radiator cooling fan is 130 kW 175 HP.



TRANSMISSION

Torque converter:
 Type3-element, 1-stage, 1-phase
 Transmission:
 TypeAutomatic full-powershift, countershaft type
 Travel speed: km/h
 Measured with 23.5-25 tires

	1st	2nd	3rd	4th
Forward	6.6	11.5	20.2	34.0
Reverse	7.1	12.3	21.5	35.5

Measured with 20.5-25 tires

	1st	2nd	3rd	4th
Forward	6.0	10.6	18.6	31.1
Reverse	6.5	11.3	19.9	33.0



AXLES AND FINAL DRIVES

Drive systemFour-wheel drive
 FrontFixed, semi-floating
 RearCenter-pin support, semi-floating,
 26° total oscillation
 Reduction gearSpiral bevel gear
 Differential gearConventional type
 Final reduction gearPlanetary gear, single reduction



BRAKES

Service brakesHydraulically actuated,
 wet disc brakes actuate on four wheels
 Parking brakeWet disc brake
 Emergency brakeParking brake is commonly used



STEERING SYSTEM

TypeArticulated type, full-hydraulic power steering
 Steering angle35° each direction (40° end stop)
 Minimum turning radius at
 the center of outside tire6320 mm



HYDRAULIC SYSTEM

Steering system:
 Hydraulic pumpPiston pump
 Capacity138 L/min at rated rpm
 Relief valve setting24.5 MPa 250 kg/cm²
 Hydraulic cylinders:
 TypeDouble-acting, piston type
 Number of cylinders2
 Bore x stroke75 mm x 442 mm

Loader control:
 Hydraulic pumpPiston pump
 Capacity205.5 L/min
 Relief valve setting31.4 MPa 320 kg/cm²
 Hydraulic cylinders:
 TypeDouble-acting, piston type
 Number of cylinders—bore x stroke:
 Lift cylinder2- 130 mm x 713 mm
 Bucket cylinder1- 150 mm x 535 mm
 Control valve2-spool type
 Control positions:
 BoomRaise, hold, lower, and float
 BucketTilt-back, hold, and dump
 Hydraulic cycle time (rated load in bucket)
 Raise5.9 s
 Dump1.8 s
 Lower (Empty)3.3 s



SERVICE REFILL CAPACITIES

Cooling system29.1 L
 Fuel tank300 L
 Engine23 L
 Hydraulic system139 L
 Axle (each front and rear)40 L
 Torque converter and transmission38 L



BUCKET SELECTION GUIDE

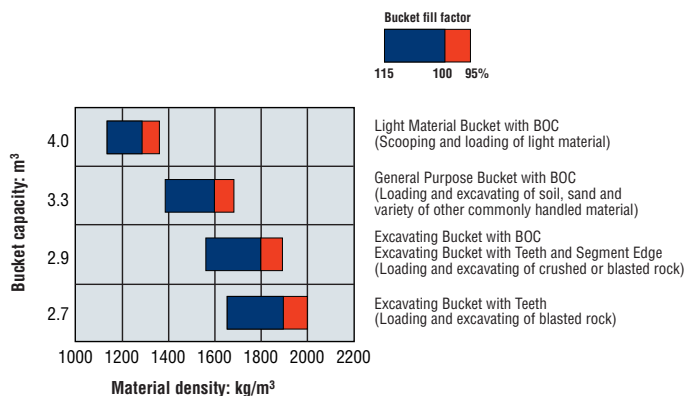



DIMENSIONS

Measured with 23.5-25-16PR (L-3) tires, ROPS/FOPS cab

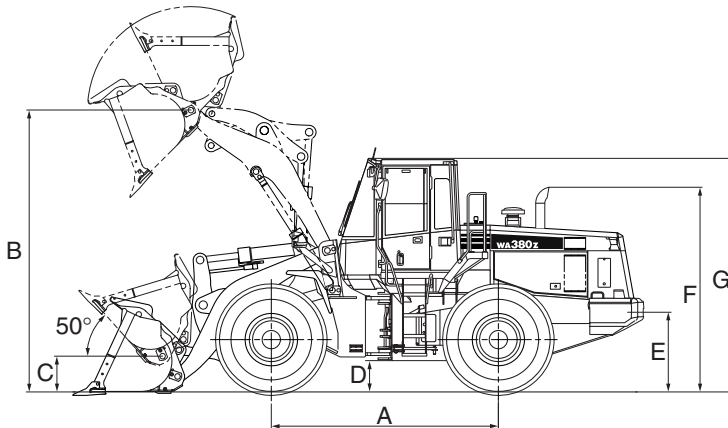

Tread	2160 mm
Width over tires	2780 mm
A Wheelbase	3300 mm
B Hinge pin height, max. height	4095 mm
C Hinge pin height, carry position	520 mm
D Ground clearance	455 mm
E Hitch height	1150 mm
F Overall height, top of the stack	2975 mm
G Overall height, ROPS cab	3390 mm

	General Purpose Buckets		Excavating Buckets			Light Material Bucket
	Bolt-on Cutting Edges	Teeth	Bolt-on Cutting Edges	Teeth and Segments	Teeth	Bolt-on Cutting Edges
Bucket capacity: heaped	3.3 m ³	3.1 m ³	2.9 m ³	2.9 m ³	2.7 m ³	4.0 m ³
struck	2.9 m ³	2.7 m ³	2.4 m ³	2.4 m ³	2.3 m ³	3.4 m ³
Bucket width	2905 mm	2925 mm	2905 mm	2925 mm	2925 mm	2905 mm
Bucket weight	1620 kg	1540 kg	1720 kg	1765 kg	1645 kg	1835 kg
Dumping clearance, max. height and 45° dump angle*	2950 mm	2825 mm	3025 mm	2905 mm	2905 mm	2855 mm
Reach at max. height and 45° dump angle*	1150 mm	1240 mm	1045 mm	1140 mm	1140 mm	1220 mm
Reach at 2130 mm clearance and 45° dump angle	1730 mm	1765 mm	1675 mm	1715 mm	1715 mm	1755 mm
Reach with arm horizontal and bucket level	2585 mm	2745 mm	2445 mm	2615 mm	2615 mm	2710 mm
Operating height (fully raised)	5600 mm	5600 mm	5485 mm	5485 mm	5485 mm	5735 mm
Overall length	8140 mm	8295 mm	8000 mm	8155 mm	8155 mm	8265 mm
Loader clearance circle (bucket at carry, outside corner of bucket)	14420 mm	14520 mm	14350 mm	14450 mm	14450 mm	14480 mm
Digging depth: 0°	60 mm	75 mm	60 mm	75 mm	75 mm	60 mm
10°	290 mm	335 mm	270 mm	315 mm	315 mm	315 mm
Static tipping load: straight	14415 kg	14560 kg	14360 kg	14335 kg	14485 kg	14075 kg
40° full turn	12470 kg	12610 kg	12410 kg	12380 kg	12530 kg	12140 kg
Breakout force	158 kN 16100 kg	170 kN 17300 kg	176 kN 18000 kg	183 kN 18700 kg	191 kN 19500 kg	144 kN 14700 kg
Operating weight	17200 kg	17130 kg	17300 kg	17350 kg	17230 kg	17420 kg

* At the end of tooth or B.O.C.

All dimensions, weights, and performance values based on SAE J732c and J742b standards.

Static tipping load and operating weight shown include lubricant, coolant, full fuel tank, ROPS cab, and operator. Machine stability and operating weight affected by counterweight, tire size, and other attachments.

Apply the following weight changes to operating weight and static tipping load.



WEIGHT CHANGES

Tires or attachments	Operating weight	Tipping load straight	Tipping load full turn	Width over tires	Ground clearance	Change in vertical dimensions
	kg	kg	kg	mm	mm	mm
23.5-25-16PR(L-3)	0	0	0	2780	455	0
20.5-25-16PR(L-3)	-970	-770	-680	2695	390	-65
Install additional counterweight	+340	+900	+755			



STANDARD EQUIPMENT

- 2-spool valve for boom and bucket controls
- Air conditioner
- Alternator, 60 A
- Auto shift transmission with mode select system
- Back-up alarm
- Back-up lamp
- Batteries, 2 x 12 V/136 Ah
- Boom kick-out
- Bucket positioner
- Counterweight
- Directional signal
- Engine, Komatsu SAA6D107E-1 diesel
- Engine shut-off system, electric
- Floor mat
- Front fender
- Fuel prefilter with water separator
- Hydraulic-driven fan
- Lift cylinders and bucket cylinder
- Loader linkage with standard lift boom
- Main monitor panel with EMMS (Equipment Management Monitoring System)
- PPC fingertip control, two levers
- Radiator mask
- Rear view mirror
- Rear window washer and wiper
- ROPS/FOPS cab
- Seat, suspension type with reclining
- Seat belt
- Service brakes, wet disc type
- Starting motor, 5.5 kW/24 V
- Steering wheel, tiltable
- Sun visor
- Tires (23.5-25-16PR, L-3 tubeless) and rims
- Transmission, 4 forward and 4 reverse
- Water separator



OPTIONAL EQUIPMENT

- 3-spool valve
- Additional counterweight
- AM/FM radio
- Batteries, 2 x 12V/140 Ah
- Bucket teeth (bolt-on type)
- Bucket teeth (tip type)
- Counterweight for log
- Cutting edge (bolt-on type)
- Deluxe suspension seat
- Emergency steering (SAE)
- Engine pre-cleaner with extension
- High lift boom
- Limited slip differential (F&R)
- Log grapple
- Mud guard
- Ordinary spare parts
- Power train guard
- Rear under view mirror
- Tool kit
- Vandalism protection kit

www.Komatsu.com

Printed in Japan 201208 IP.SIN

KOMATSU®

CEN00480-01

Materials and specifications are subject to change without notice
KOMATSU is a trademark of Komatsu Ltd. Japan